



TouchMATRIX® Indicator DM350

Process indicator with two 16 bit analog inputs, touch screen and graphic display for DMS full bridge sensor

Product Features:

- Helle Bright and high-contrast display with event-dependent color variations
- Emulation of a 7-segment display inclusively icons and units
- Intuitive and easy parameterization by plain text and touchscreen
- Connection for one independent DMS full bridge sensor
- One independent analog current/voltage output
- Three HTL inputs for triggering different states
- Four outputs to indicate different states
- 3.78 x 1.89 inch norm panel housing and IP65 protection

Available Options:

DM350: Basic unit for DMS full bridge sensor, 3 control inputs

- Option **AC:** power supply 115...230 VAC
- Option **AO:** 16 bit analog output, 4 control outputs, serial RS232 interface
- Option **AR:** 16 bit analog output, 4 control outputs, serial RS485 interface
- Option **CO:** 4 control outputs, serial RS232 interface
- Option **CR:** 4 control outputs, serial RS485 interface
- Option **RL:** 2 relay outputs

Die deutsche Beschreibung ist verfügbar unter:

https://www.motrona.com/fileadmin/files/bedienungsanleitungen/Dm350_d.pdf



The English description is available at:

https://www.motrona.com/fileadmin/files/bedienungsanleitungen/Dm350_e.pdf



La description en français est disponible sur:

https://www.motrona.com/fileadmin/files/bedienungsanleitungen/Dm350_f.pdf



The operator software OS (freeware) is available at:

<https://www.motrona.com/en/support/software.html>



Version:	Description:
DM350_01a/AF/mbo/ June 2023	First Version
DM350_01b/mbo/Dec. 2023	Various modifications

Legal notices:
All contents included in this manual are protected by the terms of use and copyrights of motrona GmbH. Any reproduction, modification, usage or publication in other electronic and printed media as well as in the internet requires prior written authorization by motrona GmbH.

Table of Contents

1.	Safety Instructions and Responsibility	5
1.1.	General Safety Instructions	5
1.2.	Use according to the intended purpose.....	5
1.3.	Installation.....	6
1.4.	EMC Guidelines.....	7
1.5.	Cleaning, Maintenance and Service Notes.....	7
2.	Introduction	8
3.	Block diagram for DM350	8
4.	Electrical Connections DM350.....	9
4.1.	DC Power Supply (GND, 24V)	9
4.2.	DMS Full Bridge Supply (SUP+/-)	9
4.3.	DMS Full Bridge Readback (MEA+/-)	9
4.4.	DMS Full Bridge Voltage (BRI-/+)	9
4.5.	Example of Connection DMS Sensor.....	10
4.6.	Control Outputs (Ctrl. OUTx, COM+)	10
4.7.	Control Inputs (Ctrl. INx).....	10
4.8.	Analog Outputs (AGND, 20 mA, $\pm 10V$)	11
4.9.	Serial Interface (GND, RxD/B, TxD/A)	11
4.10.	AC Power Supply (115-230V~, 0V~).....	12
4.11.	Relay-Outputs (CO/NO/NC Rel.x)	12
5.	Operation and Touch Screen.....	13
5.1.	Screen Structure for Parametrization	13
5.2.	Screen Structure in Operation	14
5.3.	Error Messages	15
6.	Parameter.....	16
6.1.	General Menu	16
6.2.	Sensor Menu	19
6.3.	Preselection Menu	21
6.4.	Output 1-4 Menu	22
6.5.	Relay 1-2 Menu	24
6.6.	Serial Menu	26
6.7.	Analog Output Menu.....	29
6.8.	Digital Input Menu	30
6.9.	Display Menu	31
6.10.	Adjustment Menu	33
7.	Commissioning	35
7.1.	Basic Setting of the DMS Sensor	35
7.2.	Simplest Setting.....	35
7.3.	Conversion to Sensor Units.....	37
7.4.	Digital Input.....	38
7.5.	Analog Output	38
7.6.	Digital Output.....	38
7.7.	Additional Optional Settings	38
7.7.1.	Examination of the Read Analog Values	38

7.7.2.	Setting of the Serial Interface	38
7.8.	Calibration of Analog Output	39
7.9.	Calibration of MEA Readback.....	39
7.10.	Calibration of Analog Input BRI / DMS	39
7.10.1.	Calibration of Input Stage.....	39
7.10.2.	Calibration of Input Stage and of DMS Sensors.....	40
7.10.3.	Monitor Codes for Calibration	41
8.	Input Functions	42
8.1.	Reset / Set.....	42
8.2.	Analog Set.....	42
8.3.	Release Out 1	42
8.4.	Release Out 2	43
8.5.	Release Out 3	43
8.6.	Release Out 4	43
8.7.	Release Rel 1	44
8.8.	Release Rel 2	44
8.9.	Release All	44
9.	Output Functions.....	45
9.1.	Output Function = 1	45
9.2.	Output Function = 2.....	45
9.3.	Output Function = 3.....	45
9.4.	Output Function = 4.....	45
9.5.	Output Function = 5.....	45
9.6.	Output Function = 6.....	45
9.7.	Output Function = 7.....	45
10.	Lecom Protocol	47
10.1.	Lecom Read	47
10.2.	Lecom Write	48
11.	Modbus Protocol.....	49
11.1.	Modbus Read	49
11.2.	Modbus Write	50
12.	Parameter List	53
13.	Dimensions.....	56
14.	Technical Specifications.....	57

1. Safety Instructions and Responsibility

1.1. General Safety Instructions

This operation manual is a significant component of the unit and includes important rules and hints about the installation, function and usage. Non-observance can result in damage and/or impairment of the functions to the unit or the machine or even in injury to persons using the equipment!

Please read the following instructions carefully before operating the unit and observe all safety and warning instructions! Keep the manual for later use.

A pertinent qualification of the respective staff is a fundamental requirement in order to use this manual. The unit must be installed, connected and put into operation by a qualified electrician.

Liability exclusion: The manufacturer is not liable for personal injury and/or damage to property and for consequential damage, due to incorrect handling, installation and operation. Further claims, due to errors in the operation manual as well as misinterpretations are excluded from liability.

In addition, the manufacturer reserves the right to modify the hardware, software or operation manual at any time and without prior notice. Therefore, there might be minor differences between the unit and the descriptions in operation manual.

The raiser respectively positioner is exclusively responsible for the safety of the system and equipment where the unit will be integrated.

During installation or maintenance all general and also all country- and application-specific safety rules and standards must be observed.

If the unit is used in processes, where a failure or faulty operation could damage the system or injure persons, appropriate precautions to avoid such consequences must be taken

1.2. Use according to the intended purpose

The unit is intended exclusively for use in industrial machines, constructions and systems. Non-conforming usage does not correspond to the provisions and lies within the sole responsibility of the user. The manufacturer is not liable for damages which has arisen through unsuitable and improper use.

Please note that unit may only be installed in proper form and used in a technically perfect condition (in accordance to the Technical Specifications, see chapter [14](#)). The unit is not suitable for operation in explosion-proof areas or areas which are excluded by the EN 61010-1 standard.

1.3. Installation

The unit is only allowed to be installed and operated within the permissible temperature range. Please ensure an adequate ventilation and avoid all direct contact between the unit and hot or aggressive gases and liquids.

Before installation or maintenance, the unit must be disconnected from all voltage-sources. Further it must be ensured that no danger can arise by touching the disconnected voltage-sources.

Units which are supplied by AC-voltages, must be connected exclusively by switches, respectively circuit-breakers with the low voltage network. The switch or circuit-breaker must be placed as near as possible to the unit and further indicated as separator.

Incoming as well as outgoing wires and wires for extra low voltages (ELV) must be separated from dangerous electrical cables (SELV circuits) by using a double resp. increased isolation.

All selected wires and isolations must be conformed to the provided voltage- and temperature-ranges. Further all country- and application-specific standards, which are relevant for structure, form and quality of the wires, must be ensured. Indications about the permissible wire cross-sections for wiring are described in the Technical Specifications (see chapter [14](#)).

Before first start-up it must be ensured that all connections and wires are firmly seated and secured in the screw terminals. All (inclusively unused) terminals must be fastened by turning the relevant screws clockwise up to the stop.

Overvoltages at the connections must be limited to values in accordance to the overvoltage category II.

1.4. EMC Guidelines

All motrona units are designed to provide high protection against electromagnetic interference. Nevertheless, you must minimize the influence of electromagnetic noise to the unit and all connected cables.

Therefore, the following measures are mandatory for a successful installation and operation:

- **Use shielded cables for all signal and control input and output lines.**
- **Cables for digital controls (digital I/O, relay outputs) must not exceed a length of 30 m and are allowed for in building operation only**
- Use shield connection clamps to connect the cable shields properly to earth
- The wiring of the common ground lines must be star-shaped and common ground must be connected to earth at only one single point
- The unit should be mounted in a metal enclosure with sufficient distance to sources of electromagnetic noise.
- Run signal and control cables apart from power lines and other cables emitting electromagnetic noise.

Please also refer to motrona manual "General Rules for Cabling, Grounding, Cabinet Assembly". You can download that manual by the link

<https://www.motrona.com/en/support/general-certificates.html>

1.5. Cleaning, Maintenance and Service Notes

To clean the front of the unit please use only a slightly damp (not wet!), soft cloth. For the rear no cleaning is necessary. For an unscheduled, individual cleaning of the rear the maintenance staff or assembler is self-responsible.

During normal operation no maintenance is necessary. In case of unexpected problems, failures or malfunctions the unit must be shipped for back to the manufacturer for checking, adjustment and reparation (if necessary). Unauthorized opening and repairing can have negative effects or failures to the protection-measures of the unit.

2. Introduction

The DM350 is a unit for connecting one DMS full bridge sensor, whose converted measured values are available at an analog output (current/voltage) and at four control outputs (depending on the option).

Optionally, an RS-232 or RS-485 communication interface with LECOM or MODBUS protocol is available.

The Control outputs transmit the rising above, the falling below of switching points, as well as movements outside of a range. A DMS error can also be detected.

The COM+ connection determines the voltage level of the control outputs. At 24 V this corresponds to the HTL level.

The HTL Control inputs can be used to release the self-holding at the outputs.

Furthermore, a set function of the analog output can be realized via the HTL Control inputs.

Optionally, two relay outputs can also be used as outputs.

3. Block diagram for DM350

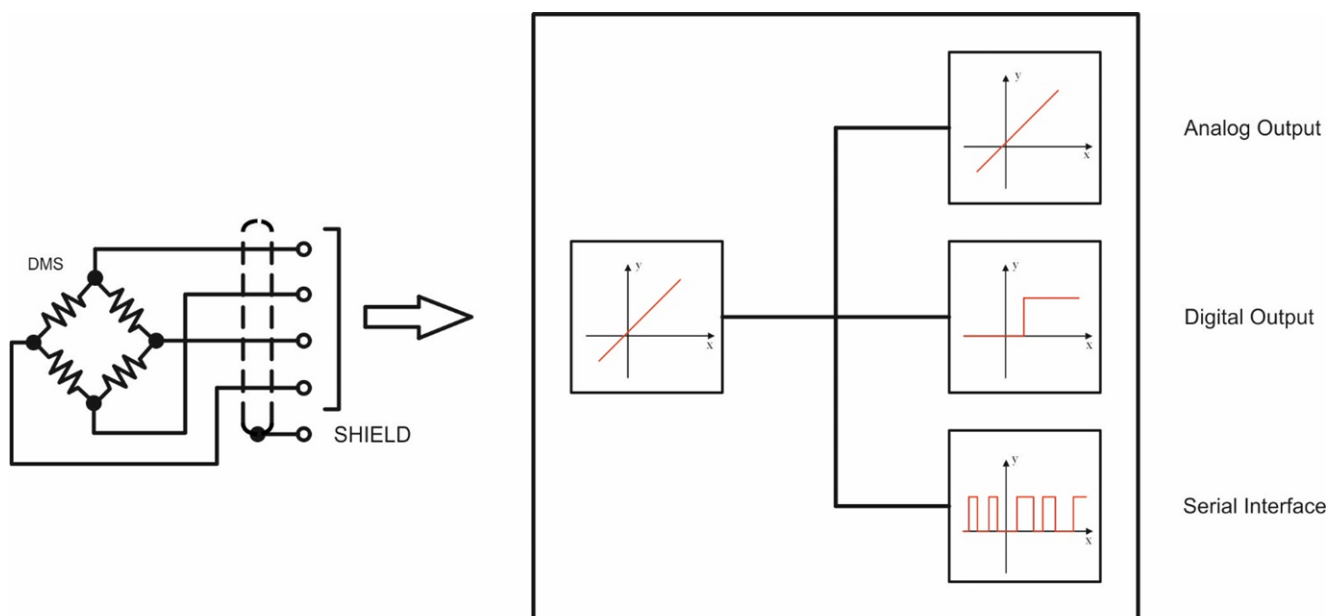

4. Electrical Connections DM350

The terminal screws should be tightened with a slotted screwdriver (blade width 2mm).

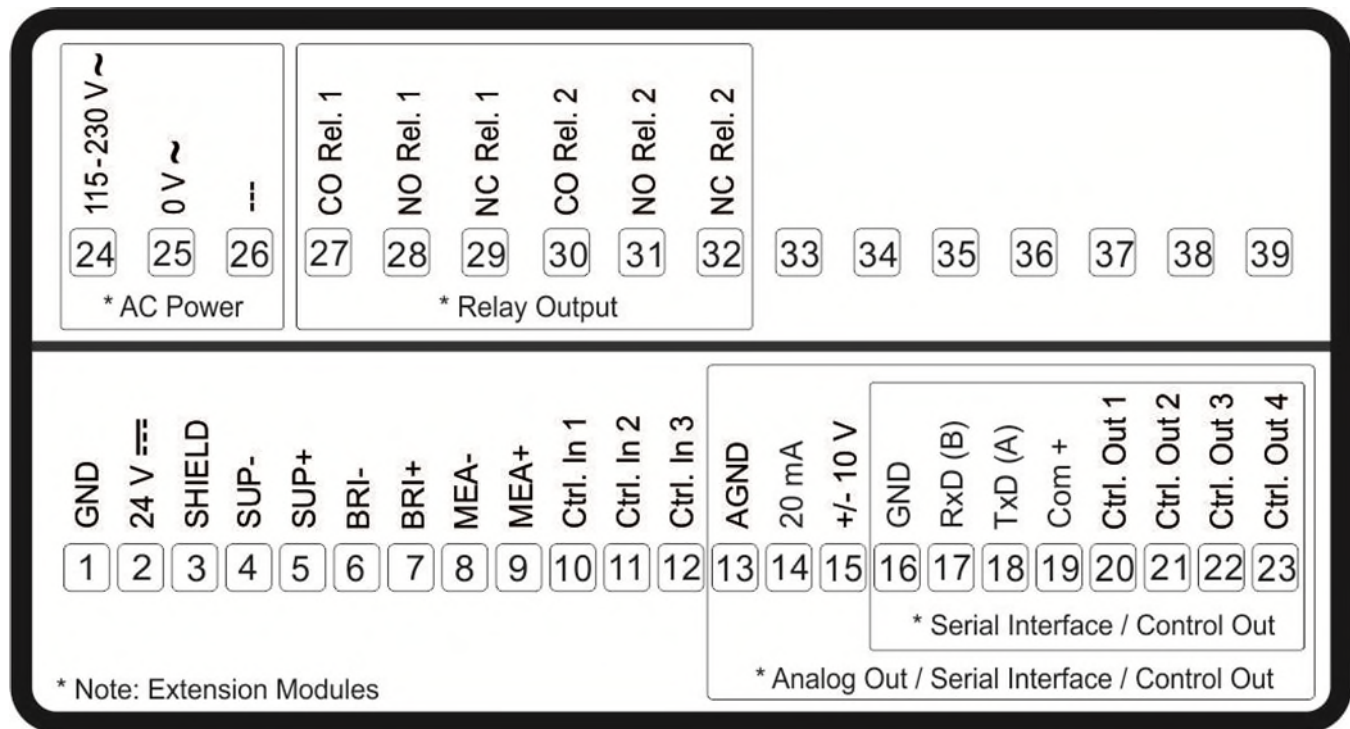

4.1. DC Power Supply (GND, 24V)

The unit accepts DC supply from 18 to 30 V at the terminals 1 (GND) and 2 (24V). The power consumption depends on the level of the supply voltage with approx. 100 mA and the additional bridge current required from the bridge voltage supply output.

4.2. DMS Full Bridge Supply (SUP+/-)

With the terminals 4 (SUP-) and 5 (SUP+) the DMS sensors can be supplied by a programmable bridge supply voltage of 3V - 10VDC with max. 50 mA.

4.3. DMS Full Bridge Readback (MEA+/-)

With the terminals 8 (MEA-) and 9 (MEA+) the DMS sensor bridge supply voltage can be read back. These terminals must be connected with SUP \pm in any case, ideally directly at the full bridge, in order to avoid voltage drops at the supply line. Read back is via monitor (page 0) by code <2.

4.4. DMS Full Bridge Voltage (BRI-/+)

With the terminals 6 (BRI-) and 7 (BRI+) the DMS bridge voltage can be evaluated. The bridge voltage in units can read back via monitor (Page 0) by the codes <4 and <5.

4.5. Example of Connection DMS Sensor

The picture below shows an example of the connection of a DMS sensor.
 (SUP = Supply, MEA = Measurement Supply, BRI = Bridge Voltage)

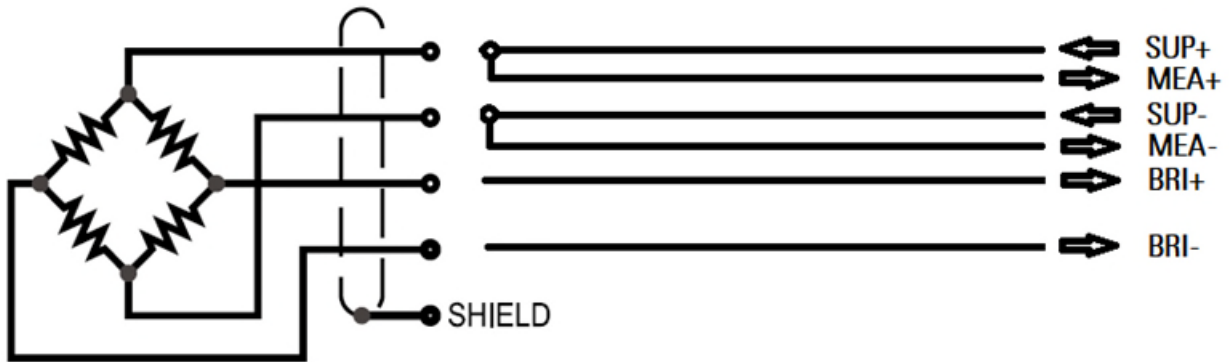

4.6. Control Outputs (Ctrl. OUTx, COM+)

At the terminal 20 to 23 (Ctrl. OUTx) four control output signals are available. Terminal 19 (COM+) supplies the outputs and thus determines the voltage level at the output. The outputs can transmit different states by the parameterization and are designed as high-side drivers. The status of the outputs is directly visible in the Outputs field of the OS.

The switching states is displayed (display with unit and status bar) as C1 to C4.

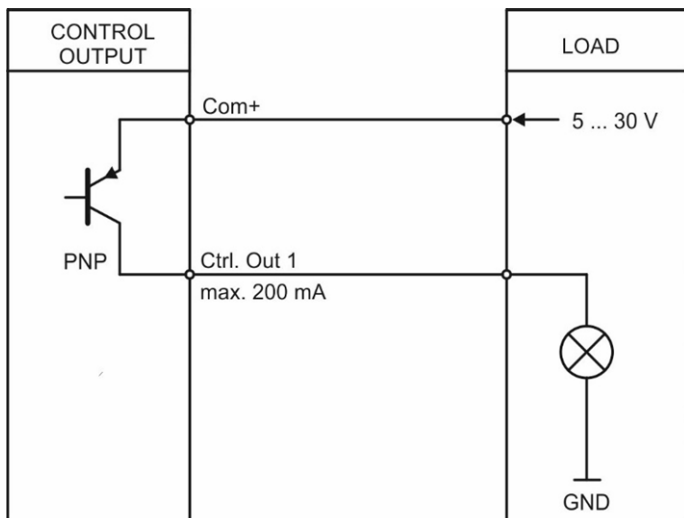

4.7. Control Inputs (Ctrl. INx)

At the terminal 10 to 12 (Ctrl. INx) three control inputs with HTL PNP characteristic (internal pull-down resistor) are available. The inputs can be used for HTL control signals. They can be programmed for different functions depending on the parameterization. The status of the inputs is directly visible in the Inputs field of the OS. The circuit below shows a PNP circuit.

Continuation "Control Inputs (Ctrl. INx)":

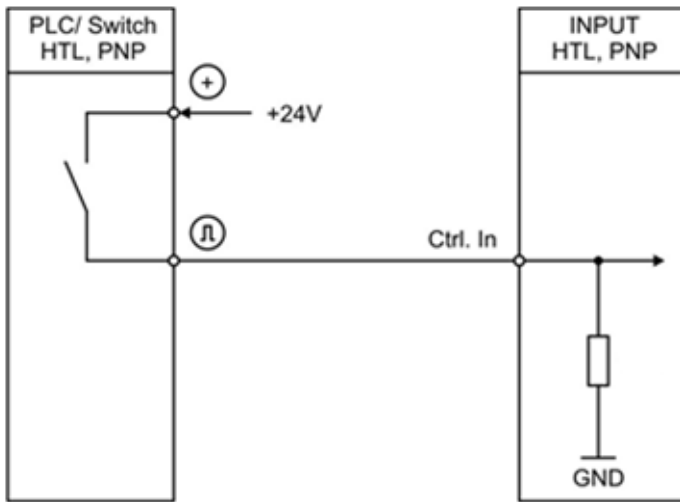

4.8. Analog Outputs (AGND, 20 mA, ± 10V)

At the outputs of the terminals 13 to 15 (AGND, 20 mA, ± 10V) a voltage output ((+/-10V, 0-10V) and a current output (0-20mA, 4-20mA) are available. The voltage output is located at the terminals 13 and 15, and the current output at the terminals 13 and 14.



Attention:
Only either the current or the voltage output may be used.

4.9. Serial Interface (GND, RxD/B, TxD/A)

A serial interface (RS232 or RS485) is available at terminal 16 to 18 (GND, RxD/B, TxD/A). The following drawing shows the connection to a PC by using a standard Sub-D-9 connector:

Connection of the RS232 interface:

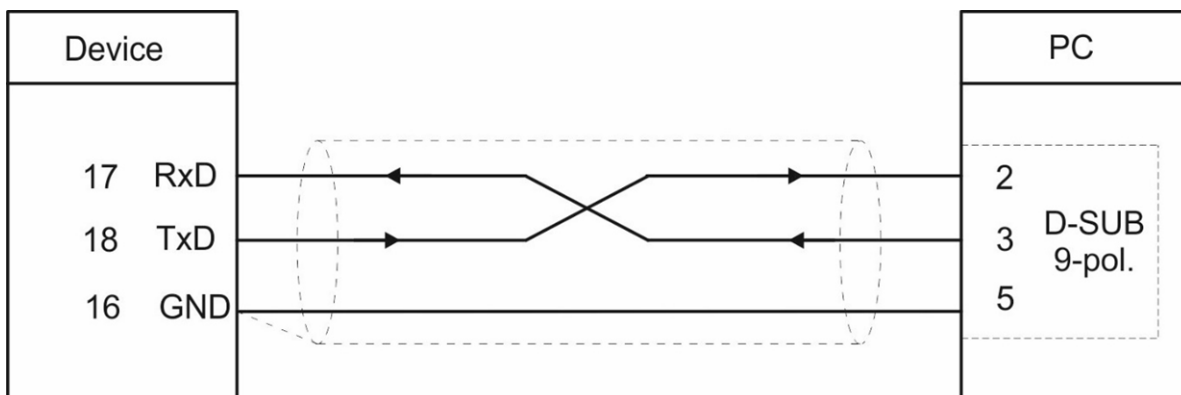

Connection of the RS485 interface:

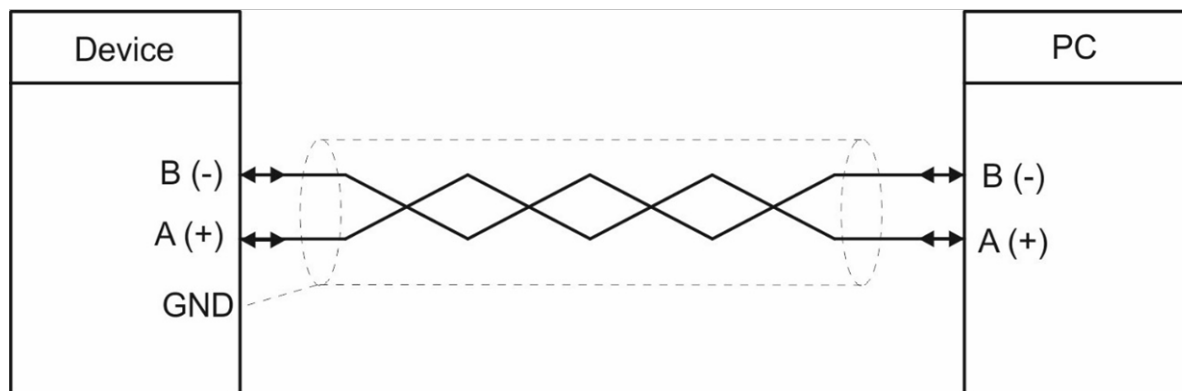

4.10. AC Power Supply (115-230V~, 0V~)

The unit accepts AC supply from 115 to 230 VAC at the terminals 24 and 25 (115-230V~, 0V~).

The power consumption depends on the level of the supply voltage with approx. 3 VA.

Devices with option AC can also be supplied with a DC voltage between 18 and 30 VDC at terminals 1 and 2.

4.11. Relay-Outputs (CO/NO/NC Rel.x)

Two relay outputs with potential-free changeover contacts are available at terminal 27 to 32.

The switching states are displayed (display with unit and status bar) as K1 and K2.

Relay type:

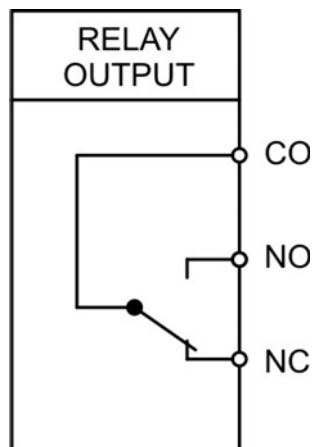

5. Operation and Touch Screen

5.1. Screen Structure for Parametrization

The parameter menus and the parameters are described in chapter [6](#).



Start setup procedure:

To edit the parameters, press the touch screen for 3 seconds. (also applies to other windows, possibly upper area, see chapter [5.2](#))

Control or relay status are only displayed with option AO, AR, CO, CR or RL



Menu selection:

Select the parameter menu via arrow buttons and confirm with "OK".

The menu selection can be terminated with „C“.

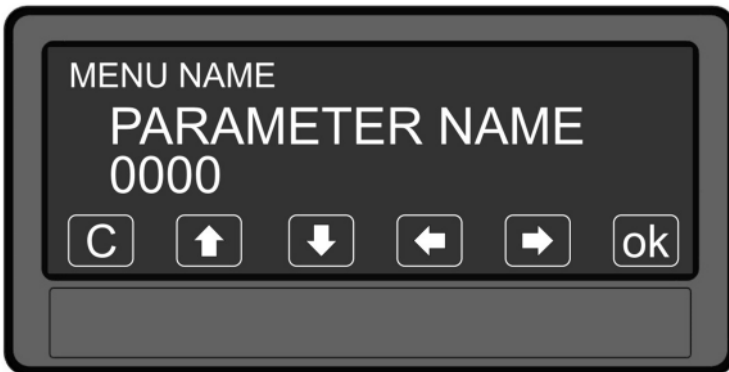

Parameter selection:

Select the parameter via arrow buttons and confirm with „OK“.

The parameter selection can be terminated with „C“.



Parameter editing:

Edit the parameter via arrow button up and down, shift cursor via left and right and save with „OK“.

The parameter editing can be terminated with „C“.

Parameter changes becomes active only after closing the parameter editing.

5.2. Screen Structure in Operation

The following screens are available during operation. Depending on the device version only certain displays are shown.



Single line display with unit and status bar

To switch to the next display, press the touch screen.

Control or relay status are only shown with Option AO, AR, CO, CR or RL.



Large Display (4 digits)

To switch to the next display, press the top of the screen.

This is only possible with activated parameter „LARGE DISPLAY“.



Display of keyboard commands

To switch to the next display, press the top of the screen.

RESET/SET resets the display to zero.
(Parameter Disable Set Key= No)
FREEZE freezes the display.



Display for enter preselection values (PRESELECTION MENU) (optional window)

To switch to the next display, press the top of the screen or SKIP.

EDIT PRESEL. causes a quick, immediate access to the PRESELECTION MENU.

Continuation "Screen Structure in Operation":



Display of the min / max values

To switch to the next display, press the top of the screen or SKIP.

RES. MIN/MAX causes a reset of the min. / max. values.

5.3. Error Messages



ERROR: MAX. LARGE DISPLAY VALUE

The display value of the large display is greater than + 9 999



ERROR: MIN. LARGE DISPLAY VALUE

The display value of the large display is less than - 999



ERROR: DEC. LARGE DISPLAY VALUE

Incorrectly selected decimal point in the large display.

Continuation "Error Messages":

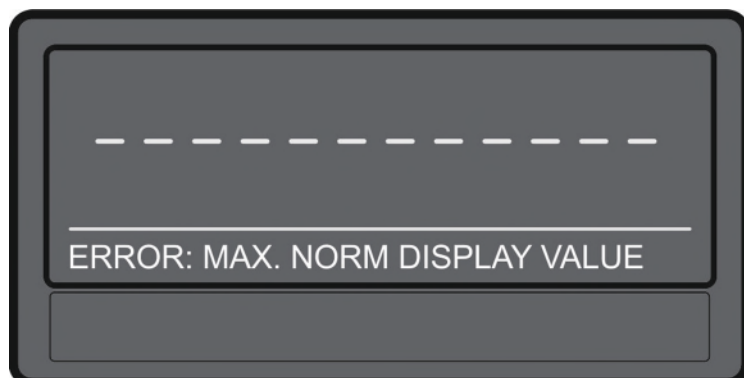

ERROR: MAX. NORM DISPLAY VALUE

The display value of the single line display is greater than +99 999 999



ERROR: MIN. NORM DISPLAY VALUE

The display value of the single line display is less than -99 999 999

6. Parameter

The parameterization of the device is realized via the touch screen or via the serial interface with a PC and the operating software OS. The link to the free download can be found on page 2.

6.1. General Menu

FILTER

This parameter provides a better filtering of the DMS sensor supply readback.

The filter time is doubled with each increase in value. The longer the filter time, the more accurate the read value.

The total read-in time can be read out on page 0 by variable <1 in ms. The total reading time is influenced by parameter SENSOR OSR and parameter FILTER.

	5	Smallest filter value (Default)
	9	Highest filter value

Continuation "General Menu":

SCALE UNITS (display measurement unit)																																																																																																		
This parameter defines the required engineering unit. This parameter does not affect the calculation of the display value. The number of decimal places must be defined with the parameter DECIMAL POINT.																																																																																																		
0	mg	Default																																																																																																
1	g																																																																																																	
2	kg																																																																																																	
3	t																																																																																																	
4	mm																																																																																																	
5	cm																																																																																																	
6	m																																																																																																	
7	mV																																																																																																	
8	V																																																																																																	
9	N																																																																																																	
10	gr																																																																																																	
11	dr																																																																																																	
12	oz																																																																																																	
13	lb																																																																																																	
14	inch																																																																																																	
15	Edit Unit	<p>A customized unit with up to 16 digits can be edited using this parameter. Pressing the "OK" button opens the Edit Unit Menu. A unit can be created using the arrow keys. The "OK" button saves the Edit Unit Menu. The "C" button closes the Edit Unit Menu.</p> <table border="1"> <tr> <td></td><td>!</td><td>"</td><td>#</td><td>\$</td><td>%</td><td>&</td><td>'</td><td>(</td><td>)</td><td>*</td><td>+</td><td>,</td><td>-</td><td>.</td><td>/</td><td>0</td><td>1</td><td>2</td><td>3</td><td>4</td><td>5</td><td>6</td><td>7</td> </tr> <tr> <td>8</td><td>9</td><td>:</td><td>;</td><td><</td><td>=</td><td>></td><td>?</td><td>@</td><td>A</td><td>B</td><td>C</td><td>D</td><td>E</td><td>F</td><td>G</td><td>H</td><td>I</td><td>J</td><td>K</td><td>L</td><td>M</td><td>N</td><td>O</td> </tr> <tr> <td>P</td><td>Q</td><td>R</td><td>S</td><td>T</td><td>U</td><td>V</td><td>W</td><td>X</td><td>Y</td><td>Z</td><td>[</td><td>\</td><td>]</td><td>^</td><td>_</td><td>`</td><td>a</td><td>b</td><td>c</td><td>d</td><td>e</td><td>f</td><td>g</td> </tr> <tr> <td>h</td><td>i</td><td>j</td><td>k</td><td>l</td><td>m</td><td>n</td><td>o</td><td>p</td><td>q</td><td>r</td><td>s</td><td>t</td><td>u</td><td>v</td><td>w</td><td>x</td><td>y</td><td>z</td><td>{</td><td> </td><td>}</td><td>~</td><td></td> </tr> </table>		!	"	#	\$	%	&	'	()	*	+	,	-	.	/	0	1	2	3	4	5	6	7	8	9	:	;	<	=	>	?	@	A	B	C	D	E	F	G	H	I	J	K	L	M	N	O	P	Q	R	S	T	U	V	W	X	Y	Z	[\]	^	_	`	a	b	c	d	e	f	g	h	i	j	k	l	m	n	o	p	q	r	s	t	u	v	w	x	y	z	{		}	~	
	!	"	#	\$	%	&	'	()	*	+	,	-	.	/	0	1	2	3	4	5	6	7																																																																											
8	9	:	;	<	=	>	?	@	A	B	C	D	E	F	G	H	I	J	K	L	M	N	O																																																																											
P	Q	R	S	T	U	V	W	X	Y	Z	[\]	^	_	`	a	b	c	d	e	f	g																																																																											
h	i	j	k	l	m	n	o	p	q	r	s	t	u	v	w	x	y	z	{		}	~																																																																												

Continuation "General Menu":

DECIMAL POINT		
This value defines the position of the decimal point.		
OS	Display	
0	NO	No decimal point
1	0000000.0	Decimal point at the specified position
2	000000.00	Decimal point at the specified position
3	00000.000	Decimal point at the specified position (Default)
4	0000.0000	Decimal point at the specified position
5	000.00000	Decimal point at the specified position
6	00.000000	Decimal point at the specified position
7	0.0000000	Decimal point at the specified position

PIN PRESELECTION (lock function of the preselection value menu)		
This parameter defines the PIN-code for the lock function of the PRESELECTION MENU by using the button EDIT PRESEL. (master PIN 6079).		
This lock function via button EDIT PRESEL. is only useful in conjunction with active lock function in PIN PARAMETER, because otherwise the preselections can be selected via the open lock function PARAMETER.		
	0000	No lock (Default)
	...	
	9999	Access after entering PIN-Code 9999

PIN PARAMETER (lock function of the parameters)		
This parameter defines the PIN-code for lock function of all parameters (master PIN 6079).		
	0000	No lock (Default)
	...	
	9999	Parameterization of the unit after entering PIN-code 9999

FACTORY SETTING (default values)		
OS	Display	
0	NO	No default values are loaded (Default)
1	YES	Load default values of all parameters

CALCULATION MODE (calculation type)		
OS	Display	
0	DIRECT	Direct value is used for display (Default).
1	RECALCULATION	Recalculated value is used for display

DISABLE SET KEY (deactivation of the SET key in the display)		
Prevents accidental triggering of zeroing when displaying via keyboard command		
OS	Display	
0	NO	Zeroing by button is possible (Default)
1	YES	Zeroing by button is not possible

6.2. Sensor Menu

SENSOR SUPPLY (sensor bridge power supply)

This parameter sets the supply of the sensor in V. The setting 5 corresponds to a voltage of approx. 5V. (Readback via Monitor Page 0 Code <2, calibration by parameter Vin Mea. Gain)

	3	Corresponds to a bridge supply voltage of 3V
	5	Corresponds to a bridge supply voltage of 5V (Default)
	10	Corresponds to a bridge supply voltage of 10V

SENSOR GAIN

This parameter sets the amplification of bridge voltage 1. A setting of Gain = 0, 1, 2, 3, 4 results a gain of 1, 2, 4, 8, 16.

	OS	Display	
	0	x 1	Corresponds to a range of +/- 80mV (Default)
	1	x 2	Corresponds to a range of +/- 40mV
	2	x 4	Corresponds to a range of +/- 20mV
	3	x 8	Corresponds to a range of +/- 10mV
	4	x 16	Corresponds to a range of +/- 5mV

SENSOR OSR (sensor oversampling)

This parameter sets the oversampling of bridge voltage. The oversampling doubles with each step. The larger oversampling value results in a more accurate the read-in value.

The total time can be read out on page 0 by variable <1 in ms and is influenced by parameter OSR and the filter.

	5	Smallest OSR value (Default)
	12	Highest OSR value

SENSOR OFFSET (sensor distance)

This parameter sets the offset of bridge voltage. This parameter is also used for the Set/Reset function of the inputs and thus overwritten but not permanently saved. Without using the inputs, the offset can be set permanently.

	-10000	Smallest offset value
	0	Default value
	+10000	Highest offset value

SENSOR RESISTOR

This parameter is used to set the bridge resistance (input resistance) of the sensor. This value can be monitored by the DM. For example, if 350 ohms is set, an error will be triggered at $R < 175$ ohms and $R > 700$ ohms. (/2 or *2)

(Monitor Page 0 code <2)

If the value is set to 0, no error can be detected.

	0	Smallest resistor value
	1000	Default value
	10000	Highest resistor value

Continuation "Sensor Menu":

SENSOR SENSITIVITY			
This parameter sets the sensitivity (mV/V) of the sensor. This parameter is used only for certain types of calculation (setting of recalculation)			
	0.100	Smallest sensitivity value	
	1.000	Default value	
	20.000	Highest sensitivity value	
SENSOR VOLTAGE			
This parameter is used to convert the bridge voltage together with the parameter Digit. This parameter is used only for certain types of calculation (setting of recalculation)			
	1	Smallest voltage value	
	1000	Default value	
	99999	Highest voltage value	
SENSOR DIGIT (sensor units)			
This parameter is used to convert the bridge voltage together with the parameter Voltage. This parameter is used only for certain types of calculation (setting of recalculation)			
	1	Smallest digit value	
	1000	Default value	
	99999	Highest digit value	
SENSOR CORRECTION			
With this parameter a correction can be made. This parameter is used only for certain types of calculation (setting of recalculation)			
	0.990	Smallest correction value	
	1.000	Default value	
	1.100	Highest correction value	
SENSOR POLARITY			
With this parameter an inversion can be made. A positive measured bridge voltage can be changed into a negative one by the parameter. (Tension and compression with corresponding sign)			
	OS	Display	
	0	Pressure	Pressure (Default)
	1	Traction	Traction

6.3. Preselection Menu

This menu is used to set the preselection values or the switching points

This function is only available for devices with option CO, CR, A0, AR or RL.

PRESELECTION 01 (switching point for Output 1)		
	-99999999	Smallest Preselection 01 value
	...+1000...	Default value
	+99999999	Highest Preselection 01 value

PRESELECTION 02 (switching point for Output 2)		
	-99999999	Smallest Preselection 02 value
	...+2000...	Default value
	+99999999	Highest Preselection 02 value

PRESELECTION 03 (switching point for Output 3)		
	-99999999	Smallest Preselection 03 value
	...+3000...	Default value
	+99999999	Highest Preselection 03 value

PRESELECTION 04 (switching point for Output 4)		
	-99999999	Smallest Preselection 04 value
	...+4000...	Default value
	+99999999	Highest Preselection 04 value

PRESELECTION R1 (switching point for Relay 1)		
	-99999999	Smallest Preselection R1 value
	...+5000...	Default value
	+99999999	Highest Preselection R1 value

PRESELECTION R2 (switching point for Relay 2)		
	-99999999	Smallest Preselection R2 value
	...+6000...	Default value
	+99999999	Highest Preselection R2 value

6.4. Output 1-4 Menu

In this menu the parameters of the reference source, the switching conditions and further definitions for the switching point are set.

This function is only available for devices with option CO, CR, AO, AR or RL.

OUTPUT SOURCE (reference source for the output)		
This parameter defines the reference source for the output.		
OS	Display	
0	DIRECT	Reference source is direct input (Default)
1	RECALCULATED	Reference source is converted input

OUTPUT FUNCTION (switching condition for the output)		
Switching condition for the output. Output / relay / display switch according to the following condition:		
OS	Display	Parameter Output Polarity = 0 = Active High
0	NO FUNCTION	No function
1	RESULT \geq PRES	Display value is greater or equal PRESELECTION Ox, e.g. overspeed With HYSTERESIS not equal 0 the following switching condition is applied: Display value \geq PRESELECTION Ox \rightarrow High, OS = blue Display value $<$ PRESELECTION Ox – HYSTERESIS \rightarrow Low, OS = white (Default)
2	RESULT \geq PRES	Absolute value of the display value is greater or equal absolute value of PRESELECTION Ox With HYSTERESIS not equal 0 the following switching condition is applied: Display value \geq PRESELECTION Ox \rightarrow High, OS = blue Display value $<$ PRESELECTION Ox – HYSTERESIS \rightarrow Low, OS = white
3	RESULT \leq PRES	Display value is less or equal PRESELECTION Ox, e.g. underspeed With HYSTERESIS not equal 0 the following switching condition is applied: Display value \leq PRESELECTION Ox \rightarrow High, OS = blue Display value $>$ PRESELECTION Ox + HYSTERESIS \rightarrow Low, OS = white
4	RESULT \leq PRES	Absolute value of the display value is less or equal absolute value of PRESELECTION Ox With HYSTERESIS not equal 0 the following switching condition is applied: Display value \leq PRESELECTION Ox \rightarrow High, OS = blue Display value $>$ PRESELECTION Ox + HYSTERESIS \rightarrow Low, OS = white
5	RESULT $<$ >PRES	In connection with the HYSTERESIS, a frequency band (Preselection +/- Hysteresis) can be defined and monitored. PRESELECTION Ox forms the center point. With HYSTERESIS not equal 0 the following switching condition is applied: Display value $>$ PRESELECTION Ox + HYSTERESIS \rightarrow High, OS = blue Display value $<$ PRESELECTION Ox – HYSTERESIS \rightarrow High, OS = blue
6	RESULT $<$ > PRES	In connection with the HYSTERESIS, a frequency band (Preselection +/- Hysteresis) can be defined and monitored. PRESELECTION Ox forms the center point. With HYSTERESIS not equal 0 the following switching condition is applied: Display value $>$ PRESELECTION Ox + HYSTERESIS \rightarrow High, OS = blue Display value $<$ PRESELECTION Ox – HYSTERESIS \rightarrow High, OS = blue
7	ERROR SET	DMS error Error = High, OS = blue No error = Low, OS = white

Continuation "Output 1-4 Menu":

OUTPUT HYSTERESIS (switching distance of the output) Switching distance of the output.		
OS	Display	
0		No switching distance (Default)
...		
9999		Switching distance from 9999

OUTPUT POLARITY Polarity of the output.		
OS	Display	
0	ACTIVE HIGH	Active "HIGH" (Default)
1	ACTIVE LOW	Active "LOW"

OUTPUT RELEASE (self-holding for the output) Self-holding for the output.		
OS	Display	
0	NO	No self-holding (Default)
1	YES	Self-holding

OUTPUT EVENT COLOR (color change of the output) Event-depending change of the display color. EVENT COLOR 1 has the lowest priority. EVENT COLOR 2 ... 4 are allowed to overwrite this color change.		
OS	Display	
0	NO CHANGE	No color change (Default at Output 2, 3, 4 Menu)
1	CHANGE TO RED	Color change to red
2	CHANGE TO GREEN	Color change to green
3	CHANGE TO YELLOW	Color change to yellow (Default at Output 1 Menu)

6.5. Relay 1-2 Menu

In this menu the parameters of the reference source, the switching conditions and further definitions for the switching point are set.

This function is only available for devices with option CO, CR, AO, AR or RL

OUTPUT SOURCE (reference source for the output)		
This parameter defines the reference source for the output.		
OS	Display	
0	DIRECT	Reference source is direct input (Default)
1	RECALCULATED	Reference source is converted input

OUTPUT FUNCTION (switching condition for the output)		
Switching condition for the output. Output / relay / display switch according to the following condition:		
OS	Display	Parameter Output Polarity = 0 = Active High
0	NO FUNCTION	No function
1	RESULT \geq PRES	Display value is greater or equal PRESELECTION Rx, e.g. overspeed With HYSTERESIS not equal 0 the following switching condition is applied: Display value \geq PRESELECTION Rx \rightarrow CO closes NO, OS = blue Display value $<$ PRESELECTION Rx – HYSTERESIS \rightarrow CO opens NO, OS = white (Default)
2	RESULT \geq PRES	Absolute value of the display value is greater or equal absolute value of PRESELECTION Rx With HYSTERESIS not equal 0 the following switching condition is applied: Display value \geq PRESELECTION Rx \rightarrow CO closes NO, OS = blue Display value $<$ PRESELECTION Rx – HYSTERESIS \rightarrow CO opens NO, OS = white
3	RESULT \leq PRES	Display value is less or equal PRESELECTION Rx, e.g. underspeed With HYSTERESIS not equal 0 the following switching condition is applied: Display value \leq PRESELECTION Ox \rightarrow CO closes NO, OS = blue Display value $>$ PRESELECTION Ox + HYSTERESIS \rightarrow CO opens NO, OS = white
4	RESULT \leq PRES	Absolute value of the display value is less or equal absolute value of PRESELECTION Rx With HYSTERESIS not equal 0 the following switching condition is applied: Display value \leq PRESELECTION Rx \rightarrow CO closes NO, OS = blue Display value $>$ PRESELECTION Rx + HYSTERESIS \rightarrow CO opens NO, OS = white
5	RESULT $<$ >PRES	In connection with the HYSTERESIS, a frequency band (Preselection +/- Hysteresis) can be defined and monitored. PRESELECTION Rx forms the center point. With HYSTERESIS not equal 0 the following switching condition is applied: Display value $>$ PRESELECTION Rx + HYSTERESIS \rightarrow CO opens NO, OS = white Display value $<$ PRESELECTION Rx – HYSTERESIS \rightarrow CO opens NO, OS = white
6	RESULT $<$ > PRES	In connection with the HYSTERESIS, a frequency band (Preselection +/- Hysteresis) can be defined and monitored. PRESELECTION Rx forms the center point. With HYSTERESIS not equal 0 the following switching condition is applied: Display value $>$ PRESELECTION Rx + HYSTERESIS \rightarrow CO opens NO, OS = white Display value $<$ PRESELECTION Rx – HYSTERESIS \rightarrow CO opens NO, OS = white
7	ERROR SET	DMS error Error = CO closes NO, OS = blue No error = CO opens NO, OS = white

Continuation "Relay 1-2 Menu":

OUTPUT HYSTERESIS (switching distance of the output) Switching distance of the output.		
OS	Display	
0		No switching distance (Default)
...		
9999		Switching distance from 9999

OUTPUT POLARITY Polarity of the output.		
OS	Display	
0	ACTIVE HIGH	Active "HIGH" (Default)
1	ACTIVE LOW	Active "LOW"

OUTPUT RELEASE (self-holding for the output) Self-holding for the output.		
OS	Display	
0	NO	No self-holding (Default)
1	YES	Self-holding

OUTPUT EVENT COLOR (color change of the output) Event-depending change of the display color. EVENT COLOR 1 has the lowest priority. EVENT COLOR 2 ... 4 are allowed to overwrite this color change.		
OS	Display	
0	NO CHANGE	No color change (Default at Relay 1 Menu)
1	CHANGE TO RED	Color change to red
2	CHANGE TO GREEN	Color change to green
3	CHANGE TO YELLOW	Color change to yellow (Default at Relay 2 Menu)

6.6. Serial Menu

This menu defines the basic settings of serial interface.

This function is only available for devices with option CO, CR, AO, AR or RL.

SERIAL UNIT NR. (Address)		
This parameter defines serial device addresses. The addresses between 11 and 99 can be assigned to the devices. Addresses with zero are <u>not</u> allowed, there are used as broadcast addresses.		
	11	Smallest address (Default)
	...	
	99	Highest address

SERIAL BAUD RATE		
This parameter defines the serial baud rate		
OS	Display	
0	9600	9600 baud (Default)
1	19200	19200 baud
2	38400	38400 baud

SERIAL FORMAT					
This parameter defines the bit data format.					
OS	Display				
0	7-EVEN-1	7 data	Parity even	1 Stop (Default)	
1	7-EVEN-2	7 data	Parity even	2 Stops	
2	7-ODD-1	7 data	Parity odd	1 Stop	
3	7-ODD-2	7 data	Parity odd	2 Stops	
4	7-NONE-1	7 data	no Parity	1 Stop	
5	7-NONE-2	7 data	no Parity	2 Stops	
6	8-EVEN-1	8 data	Parity even	1 Stop	
7	8-ODD-1	8 data	Parity odd	1 Stop	
8	8-NONE-1	8 data	no Parity	1 Stop	
9	8-NONE-2	8 data	no Parity	2 Stops	

SERIAL INIT (initialization)		
This parameter defines the baud rate for the initialization to the user interface OS. With settings larger than 9600 the initialization time can be reduced		
OS	Display	
0	NO	Initialization with 9600 baud. Then the device operates with the value selected by the user.
1	YES	Initialization with the baud rate set by SERIAL BAUD RATE. Then the device operates with the value selected by the user.

Continuation "Serial Menu":

SERIAL PROTOCOL												
Sets the string for a timed transmission (xxxxxxx = value SERIAL VALUE).												
	0	Transmission report = unit no., +/-, data, LF, CR (Default)										
		1	1	+/-	X	X	X	X	X	X	X	LF
	1	Transmission report = +/-, data, LF, CR										
		+/-	X	X	X	X	X	X	X	X	LF	CR

SERIAL TIMER (serial time cycle)	
This register determines the cycle time in seconds for cycling transmission of SERIAL VALUE when using the serial output. (On a serial request, the cycling transmission is stopped for 20 s)	
0.000	Cyclic transmission is switched off (Default)
...	
60.000	Time cycle in seconds

SERIAL VALUE (serial parameter)		
This parameter defines the value to be transmitted.		
Setting	Register contents	
0	Voltage output (Default)	± 10000
1	Current output	0 ... 20000
2	Read back bridge supply	in mV
3	Direct value (input)	unitless
4	Converted value (input)	unitless
5	Resistance value	R
6	Output status	(in hex 0X01 = Out1, ... etc.)
7	Input status	(in hex 0X01 = In1)
8	DMS error	
9	DMS error static	
10	Temperature	in °C
11	Bridge current	in 1/10 mA

SERIAL PAGE	
Selection of a specific variable page for internal diagnostics.	
0	Smallest Serial Page-value (Default)
...	
7	Highest Serial Page value

Continuation "Serial Menu":

MB ADDRESS This parameter enables the Modbus protocol and determines the Modbus address.		
	0	Modbus disabled Serial interface is using Lecom protocol (Motrona default protocol)
	1 ... 247	Modbus enabled: Serial interface is using Modbus RTU protocol The set value is the Modbus address of the device.

6.7. Analog Output Menu

ANALOG SOURCE (Reference source for the analog output)		
OS	Display	
0	DIRECT	For the analog output the direct converted bridge voltage of the sensor is used (Default)
1	RECALCULATED	For the analog output the converted bridge voltage of the sensor is used.

ANALOG MODE (type of analog output) Selection of analog output.		
OS	Display	
0	0V – 10V	Voltage range from 0V to 10V
1	-10V – +10V	Voltage range from $\pm 10V$ (Default)
2	0mA – 20mA	Current range from 0mA to 20mA
3	4mA – 20mA	Current range from 4mA to 20mA

ANALOG START Value at which the analog output is set to 0V or 0mA or 4mA		
	-99999999	Smallest Analog Start Preselection value
	0	Default
	99999999	Highest Analog Start Preselection value

ANALOG END Value at which the analog output is set to 10V or 20mA.		
	-99999999	Smallest Analog End Preselection value
	10000	Default
	99999999	Highest Analog End Preselection value

ANALOG SET (analog set-function) Control value for the analog output when the "Set" command appears at the control input or via the interface.		
	-99999999	Smallest Analog End Preselection value
	0	Default
	99999999	Highest Analog End Preselection value

VOUT OFFSET (voltage output calibration) Voltage offset setting for the analog output. (see analog output calibration)		
	-99	Smallest Vout Offset Preselection value
	0	Default
	99	Highest Vout Offset Preselection value

Continuation „Analog Output Menu“:

VOUT GAIN (calibration of the voltage output) Voltage Gain setting for the analog output. (see analog output calibration)		
	0.9980	Smallest Vout Gain Preselection value
	1.0000	Default
	1.0020	Highest Vout Gain Preselection value

IOUT OFFSET (calibration of the current output) Current Offset setting for the analog output. (see analog output calibration)		
	-99	Smallest Iout Offset Preselection value
	0	Default
	99	Highest Iout Offset Preselection value

IOUT GAIN (calibration of the current output) Current Gain setting for the analog output. (see analog output calibration)		
	0.9980	Smallest Iout Gain Preselection value
	1.0000	Default
	1.0020	Highest Iout Gain Preselection value

6.8. Digital Input Menu

INPUT 1-3 CONFIG (input configuration) Defines the behavior of the input.		
	OS	Display
	0	Active Low
	1	Active High
		Function triggering at a "low" state (Default)
		Function triggering at a "high" state

INPUT 1-3 FUNCTION Defines the behavior of the input.		
	0	No function (Default)
	1	Set / Reset
	2	Analog Set
	3	Release Out 1
	4	Release Out 2
	5	Release Out 3
	6	Release Out 4
	7	Release Rel 1
	8	Release Rel 2
	9	Release All
		Set/Reset for bridge voltage (zero setting)
		Set analog output to set value
		Reset of the self-holding for output OUT 1
		Reset of the self-holding for output OUT 2
		Reset of the self-holding for output OUT 3
		Reset of the self-holding for output OUT 4
		Reset of the self-holding for output REL 1
		Reset of the self-holding for output REL 2
		Reset of the self-holding for all outputs

6.9. Display Menu

DISPLAY COLOR

This parameter sets the color of the display.

Event-depending change of the display color by a switching condition is possible (see PRESELECTION 1...4 MENU). Event-depending changes are only available for devices with option CO, CR, A0, AR or RL

OS	Display	
0	RED	Red display (Default)
1	GREEN	Green display
2	YELLOW	Yellow display

DISPLAY BRIGHTNESS R (%) (brightness in red)

This parameter defines the brightness of the display in red.

10	Min. brightness
90	Default value (Default)
99	Max. brightness

DISPLAY BRIGHTNESS G (%) (brightness in green)

This parameter defines the brightness of the display in green.

10	Min. brightness
90	Default value (Default)
99	Max. brightness

DISPLAY CONTRAST

This parameter defines the contrast of the display

150	Low contrast
160	Default (best setting)
190	High contrast

DISPLAY SCREEN SAVER (switch off of the display)

This parameter defines the time in seconds until the display is switched off, after the last touch action.

0	No switch off (Default)
...	
99	Longest time to switch off

DISPLAY UPDATE TIME

This parameter defines the update time in seconds of the display.

0.100	Shortest update time in seconds
0.250	Default value, 0,25 seconds
9.999	Longest Update time in seconds

DISPLAY FONT

This parameter defines the setting of the font style

0	Standard (Default)
1	Font 1

Continuation "Display Menu":

DISPLAY START SCREEN		
This parameter defines the start display after switching on the device.		
OS	Display	
0	STANDARD	Single-line display (Default) The source must be defined in SOURCE SINGLE.
1	LARGE	Large display (only with active parameter "LARGE DISPLAY") The source must be defined in SOURCE LARGE
2	RESET / SET	Display with Reset / Set function
3	EDIT PRESEL.	Display with access to the Presel. Menu. (only with option AO, CO, RL)
4	MINIMUM/MAXIMUM	Display with actual / minimum / maximum values of input 1 and input 2

DISPLAY LARGE SCREEN		
This parameter is used to turn on or off the large display window. Using the divider ratio, the large display value can also be divided.		
OS	Display	
0	NO	Large display is switched off (Default)
1	1:1	Large display with divider ratio 1:1
2	1:10	Large display with divider ratio 1:10
3	1:100	Large display with divider ratio 1:100
4	1:1000	Large display with divider ratio 1:1000
5	1:10000	Large display with divider ratio 1:10000

6.10. Adjustment Menu

TCO ANALOG OUTPUT

Temperature compensation for the analog output.

If the parameter TCO ANALOG OUTPUT is set to 0, the output is corrected by an internal temperature measurement. This achieves better accuracy. The temperature compensation refers only to the gain of the analog output

	0	Temperature compensation on (Default)
	1	Temperature compensation off

TCI BRIDGE OFFSET

Fine adjustment of the offset temperature difference.

The temperature difference can be read out in the monitor (Page 5) using code ;8

The parameter TCI OFFSET INVERSION can be used to determine whether the value is added or subtracted.

	0.5000	Smallest TCI Bridge Offset value
	1.0000	Default
	1.5000	Highest TCI Bridge Offset value

TCI BRIDGE GAIN

Fine adjustment of the temperature gain.

The temperature gain can be read out in the monitor (page 5) using code ;9

The parameter TCI GAIN INVERSION can be used to determine whether the value has an amplifying or weakening effect.

	0.90000	Smallest TCI Bridge Gain value
	1.00000	Default
	1.10000	Highest TCI Bridge Gain value

TEMP. COMP. (TCI)

Temperature compensation for the analog input (bridge voltage).

	0	Compensation of Offset and Gain (TCI Bridge Offset / Gain active) (Default)
	1	Only Offset Compensation (TCI Bridge Offset active)
	2	Only Gain Compensation (TCI Bridge Gain active)
	3	No Compensation

BRIDGE SUPPLY ADJUST

Gain setting for the measurement of the MEA.

The setting affects the resistance calculation. If the bridge voltage is recalculated, the converted value becomes more accurate during adjustment.

The adjustment can be executed via the monitor (page 0) using code <2.

	0.8000	Smallest Bridge Supply Adjust value
	1.0000	Default
	1.2000	Highest Bridge Supply Adjust value

Continuation "Adjustment Menu":

TCI OFFSET INVERSION		
See parameter TCI Bridge Offset		
	0	Addition (Default)
	1	Subtraction
TCI GAIN INVERSION		
See parameter TCI Bridge Gain		
	0	Addition (Default)
	1	Subtraction
TEMP. SIMULATION		
If parameter TEMP. SIMULATION = 0 is set, the internal temperature sensor is used. If the parameter is set to 1, parameter TEMP. SIM. VALUE is used instead of the internal temperature sensor. This allows the temperature to be simulated and the calculation of the temperature compensation to be checked		
	0	Internal temperature sensor (Default)
	1	Parameter TEMP. SIM. VALUE
TEMP. SIM. VALUE		
Temperature simulation		
The value 870 corresponds to +60°, the value 1140 corresponds to +20° and the value 1412 corresponds to -20°.		
The current temperature can be read out by the monitor value Page 0 code ;7.		
	870	+60°
	1140	+20° (Default)
	1412	-20°
BRIDGE SUPPLY COMP. (bridge supply compensation)		
If Source = direct is selected, Compensation = 2 can be selected.		
If Source = recalculated is selected, compensation = 0 can be selected.		
	0	No compensation of the bridge voltage (Default)
	1	Compensation (increase of Supply Voltage has an amplifying effect)
	2	Compensation (increase of Supply Voltage has a weakening effect)
BRIDGE SUPPLY REF. (bridge supply reference)		
The setting of this parameter corresponds to the voltage value of the bridge supply in mV.		
	2000	Smallest Bridge Supply Ref. value
	5000	Default
	11000	Highest Bridge Supply Ref. value

7. Commissioning

7.1. Basic Setting of the DMS Sensor

For connecting or wiring see connection example for DMS sensor. After connection the parameter Supply, Gain, OSR, Resistor and Filter can be set.

Parameter Supply corresponds to the supply voltage of the DMS sensor, this can be found in the operating manual of the sensor. Values from 3 (3V) to 10 (10V) can be set for parameter Supply. The Monitor Page 0 code >2 is used to readback the supply voltage in mV, the measurement can be calibrated by parameter Bridge Supply Adjust.

Also, in the operating manual of the sensor you can find the value of the input resistance. This can be adopted for parameter Resistor. A check of the resistance value in ohms can be done by Monitor Page 0 with the code <3. A miscalibration of Bridge Supply Adjust will result in a miscalculation.

The gain should be selected so that the input voltage range is not exceeded at maximum load. At gain = 0 this is +/-80mV. This can be calculated approximately using a reference weight, for example.

Parameter OSR should be selected in dependence of Gain, so that the input fluctuation is as small as possible and the input is still dynamic enough. This also applies to parameter Filter.

The resulting read-in cycle time can be displayed in the Page 0 monitor with the code <1 in ms.

With the parameter Polarity a negative magnitude can be changed into a positive one. Thus, the user can provide tension and pressure with the corresponding sign.

Wiring faults, open connections and short circuits on the sensor can be detected by checking the monitor variables, by the Outputs field of the OS, or indicated by an output. (Read back supply voltage and calculated resistor value)



Attention:

Check whether the sensor is designed for the programmed supply voltage.
(Data sheet sensor: supply voltage)

Check if the input voltage range is within the maximum load of the sensor
(Data sheet sensor: nominal characteristic value [mV/V] x supply voltage)

7.2. Simplest Setting

The simplest setting for the analog and digital outputs is to use the directly converted bridge voltage. (Monitor Page 0 <4)

For this, parameter Analog Source must be set to 0 (DIRECT) for the analog outputs, for the digital outputs, parameter Output Source can also be set to 0.

The following parameters must be adjusted for the strain gauge sensor:

Parameter Supply: Data sheet sensor -> Permissible supply voltage of the DMS sensor

Parameter Gain: Data sheet sensor -> Sensor operating range

Parameter OSR: fluctuation of measurement and dynamics of change

Parameter Resistor: Data sheet sensor -> input resistance

Setting with zeroing:

Zeroing is necessary when forces act in both directions and the transition of e.g. tension and pressure of the input variable is to be determined in the form of the sign

Parameter Offset is decisive for zeroing. The unloaded DMS sensor can be zeroed using the Set/Reset function. The value displayed in the monitor can also be transferred directly to the offset register.

Then the monitor value displays zero. With the Set/Reset function using an input, the value is only saved temporarily, after a new power-up, it must be zeroed again

If the Set/Reset function is performed using the OS or serial communication, the value can also be saved by an OS Store Eeprom command.

Then the DMS sensor is loaded with a reference weight. A new monitor value is displayed, which corresponds to the reference weight. This value can now be converted into units for the analog and digital outputs. Based on the monitor value, you can determine the resolution in relation to the reference weight and then also optimize parameter Gain. When parameter Gain is changed, parameter Offset must also be adjusted.

Example:

Monitor value Page 0 <4: 25 at Offset = 0, DMS unloaded

Monitor value Page 0 <4: 0 at Offset = 25, DMS unloaded and zeroed

Monitor value Page 0 <4: 1000 at 5kg reference weight

It follows that at 50kg the value must be 10000. If the digital output is to switch at more than 40kg, the Preselection value must be set to 8000. If the analog output is to output at 0kg -> 0V, and at 50kg -> 10V, Analog Start = 0 and Analog End = 10000 must be set.

Setting without zeroing:

Zeroing is not necessary if the input variable is not required as a reference for the forces, that means the acting forces are not directly readable from the input variable. (e.g. value 531 -> 400g)

After that, the DMS sensor is loaded with a reference weight, a new monitor value is displayed, that corresponds to the reference weight. This value can now be converted into units for the analog and digital outputs. Based on the monitor value, you can determine the resolution in relation to the reference weight and then also optimize parameter Gain.

Example:

Monitor value Page 0 <4: 25 at Offset = 0, DMS unloaded

Monitor value Page 0 <4: 1025 at 5kg reference weight

It follows that at 50kg the value must be 10025. ($1025 - 25 = 1000$ corresponds

5kg -> 50kg = 10000, -> monitor value at 50kg = 10025)

If the digital output is to switch at more than 40kg, the Preselection value must be set to 8025.

If the analog output is to output at 0kg -> 0V, and at 50kg -> 10V, Analog Start = 25 and Analog End = 10025 must be set.

7.3. Conversion to Sensor Units

A conversion to sensor units is necessary if these quantities are to be transmitted by the interface and an external conversion is to be dispensed with. Furthermore, this type of conversion is necessary if a reference load or reference weight is not used for setting.

By using parameters Sensitivity, Voltage, Digits, and Correction, the read-in sensor value can be converted into units such as N or kg. For parameter Correction, you need a reference load or a reference weight with which the displayed value can be corrected.

Parameter Analog Source must be set to 1 for the analog outputs and parameter Output Source must be set to 1 for the digital outputs.

Parameter Offset is important for zeroing. The unloaded DMS sensor can be zeroed using the Set/Reset function. The value displayed in the monitor can also be transferred directly to the offset register. Then the monitor value displays zero. When using the Set/Reset function with the help of an input, the value is only saved temporarily; after a new power-up, it must be zeroed again.

If the Set/Reset function is operated by using the OS or serial communication, the value can also be saved by using a Store Eeprom.

Parameter Sensitivity corresponds to the sensitivity (mV/V) of the DMS sensor, this can be found in the operating manual of the sensor. The standard load or standard force can also be found here. (e.g. 2mV/V @ 100N or 10.194kg)

Parameter Sensitivity = 2,000	see data sheet
Parameter Analog Source = 1	calculation type
Parameter Voltage = 1000	Gain = 1
Parameter Digits = 10194	conversion in kg, digits in g
Parameter Correction = 1000	no correction
Parameter Offset = 133	-> 0
With a reference weight of 200g	-> input variable 54
Conversion	-> 197... 201

Attention: Here a multiplication by a factor of 4 takes place, it would be better to raise the gain to 4 if you want an accuracy to 1g.

To adjust the conversion to a small extent, parameter Correction can be used. A 1% adjustment is made by 990 or 1010.

Checking of the calculation can be done by Monitor Page 0 with code <4 (DIRECT), <5 (RECALCULATED).

Based on the monitor value, you can determine the resolution in relation to the reference weight and then also optimize parameter Gain. With changing of parameter Gain, parameter Offset must also be adjusted.

7.4. Digital Input

The digital inputs are used to trigger functions. Here the zeroing can be done by an input. A reset of the self-holding of an output, as well as the activation of the analog output with a set value is also possible.

7.5. Analog Output

In the analog output menu, the source is set by parameter Analog Source. Parameter Analog Mode can be used to differentiate between different voltage ranges and current ranges. (+/-10V, 0V-10V, 0mA-20mA or also 4mA-20mA)

Parameter Analog Start defines the source value at 0V or 0mA or also 4mA. Parameter Analog End defines the source value at 10V or 20mA.

Parameter Analog Set defines a source value within the range from start to end that can be controlled by a digital input. Thus, the analog output can also be controlled directly by the interface.

7.6. Digital Output

The digital outputs are used for the detection of states. For example, if the force exceeds a certain value, the output is set. Shortfall can also be detected. The functions can be used for forces in one direction, or in both directions.

A hysteresis can also be programmed, as well as a self-holding whose reset is only triggered again by an input.

7.7. Additional Optional Settings

7.7.1. Examination of the Read Analog Values

By using parameter Min/Max Channel, different read-in values can be examined for their scatter. Pressing the Reset Min Max = 1 button resets the minimum and maximum values. The deviations are visible directly on the display. If the values fluctuate too much, the OSR value or the filter must be increased.

7.7.2. Setting of the Serial Interface

By using parameter MB Address, the protocol of the interface can be used to set. With the setting = 0 the interface works with the Lecom protocol. If the parameter MB Address is set to a non-zero value, the Modbus protocol is used. The parameter MB Address reflects the Modbus address of the device. Different functions can be sent by Modbus or Lecom.

7.8. Calibration of Analog Output

The analog output can be calibrated individually. The set function is used for this purpose. An unconnected input can control the set values at the analog output by setting the parameters Input Config = 0 and Input Function = 2. The set value is set to 0V (analog set = analog start). By using parameter Vout Offset you can now fine-tune the offset of analog output. After that, the gain of analog output can be fine-tuned. For this purpose, the set value is set to 10V, and then the value can be corrected by parameter Vout Gain, so that exactly 10000mV are measured. (analog set = analog end).

The same procedure can be used for the current output.

7.9. Calibration of MEA Readback

The analog readback of the bridge voltage can be calibrated. For this, an external multimeter must be connected and then compared in relation to the readback via monitor. A calibration is possible by using parameter Bridge Supply Adjust. An adjustment is necessary to increase the accuracy of the calculated resistance value and when using the conversion in sensor unit. The setting must be done after the parameter Supply was selected.

7.10. Calibration of Analog Input BRI / DMS

Both analog inputs can only be calibrated in relation to the temperature.

These settings linearly correct the offset and gain depending on the temperature.

7.10.1. Calibration of Input Stage

Using different parameters, the input stage can be optimized in relation to the temperature. Using parameter Temp. Sim., the temperature for the unit can be simulated.

This makes it easy to determine the influences of individual variables. First the offset correction must take place and after that the gain correction.

Example Offset correction:

Voltage at input	0 mV
Parameter Temp. Comp. (TCI) = 1	Temperature compensation of Offset
Parameter Temp. Simulation = 1	Simulation active
Parameter Temp. Sim. Value = 1412	Simulation with -20°
Monitor Page 5 code ;7	-20 (read back temperature)
Parameter Gain = 0	Gain = 0 selected
Parameter TCI Bridge Offset = 1.0000	Standard
Parameter TCI Offset Inversion = 0	Addition
Monitor Page 5 Code ;8	-8 (back read correction at 40K)
Monitor Page 5 Code <1	Offset changes e.g. from 21 to 29 at Temp. Comp. (TCI) = 1/3

By looking at the monitor page 5 code <1 you can directly see the influence with and without temperature offset compensation and the Bridge Supply Comp. by switching. The correction is zero at 20° and is the reference point. The offset is reduced by 8 increments at -20°. At 40K the offset is corrected by 8 increments. By changing the parameter TCI Offset Inversion = 1, the code ;8 does not change, but at <1. Here the offset is then increased by 8 increments. The Gain parameter also affects the calculation, with Gain = 4, -132 increments are compensated for instead of -8. By parameter TCI Offset Inversion the 8 increments can be increased or decreased.

The following relationship applies:

Correction = (Temperature -20) x (Gain + 1) x (Gain + 1) x 2063 / TCI Bridge Offset

Correction (Temperature = -20°, Gain = 0, TCI Bridge Offset = 1.0000) = -40 x 2063 / 10000 = -8

With the standard settings, there is sufficient optimization for the input stage.

Example Gain correction:

Voltage at Input	5 mV
Parameter Temp. Comp. = 0	Temperature compensation of Offset and Gain
Parameter Temp. Sim. = 1	Simulation active
Parameter Temp. Sim. Value = 1412	Simulation with -20°
Monitor Page 5 Code ;7	-20 (read back temperature)
Monitor Page 5 Code ;8	Offset correction
Parameter Gain = 0	Gain = 0 selected
Parameter TCI Bridge Offset = 1.00000	Standard
Parameter TCI Offset Inversion = 0	Inversion
Monitor Page 5 Code ;9	Gain correction
Monitor Page 5 Code <2	Gain changes by factor at Temp. Comp. = 0/3

The following relationship applies:

Correction factor = ((Temperature -20) x (Gain + 1) +/- 100000) in dependence of TCI Bridge Offset

Correction (Temperature = -20°, Gain = 0, TCI Bridge Offset = 100000) = -40 + 100000 / 100000 = 0,9996

With the standard settings, there is sufficient optimization for the input stage.

7.10.2. Calibration of Input Stage and of DMS Sensors

Using different parameters, the input stage and the DMS can be optimized in relation to the temperature. Condition is that the DMS and the unit are exposed to approximately the same temperatures. Here, for example, the temperature-dependent offset of the DMS can be taken into account in addition to the input stage. First the offset correction must take place and after that the gain correction

7.10.3. Monitor Codes for Calibration

Calibration can be simplified by using of different monitor codes.

Monitor Page 5 Code ;7	Temperature
Monitor Page 5 Code ;8	Offset correction of the temperature influence
Monitor Page 5 Code ;9	Gain correction of the temperature influence
Monitor Page 5 Code <1	Input value (with influence of Temp. Comp. Offset and Bridge Supply Comp.)
Monitor Page 5 Code <2	Input value (additionally with influence of Temp. Comp. Gain)
Monitor Page 5 Code <3	Input value (additionally converted)

8. Input Functions

8.1. Reset / Set

The Reset / Set function zeroes the bridge voltage of DMS sensor. The current measured value is transferred to parameter Sensor Offset.

Tiggering	Parameter	Comment	Addition
Input	Input X Config = 0/1 Input X Function = 1	If Input X Config = 0 is set, the command is triggered on a "low" state at input X	The status of the input can be read in the OS Input field.
Lecom	Code 66 (dec)	Release : 04 31 31 02 36 36 30 03 33 Set : 04 31 31 02 36 36 31 03 32 (Unit no. 11, command in hex)	If 1 is written at code 66, the command is set.
Modbus	Cell FF00 (hex)	Release : 07 06 FF 00 00 00 B9 B8 Set : 07 06 FF 00 00 01 78 78 (Modbus address = 7, command in hex)	If 1 is written to cell FF00, the command is set.

8.2. Analog Set

The Analog Set function sets the analog output to the value of the Analog Set parameter.

Tiggering	Parameter	Comment	Addition
Input	Input X Config = 0/1 Input X Function = 2	If Input X Config = 0 is set, the command is triggered on a "low" state at input X.	The status of the input can be read in the OS Input field.
Lecom	Code 65 (dec)	Release : 04 31 31 02 36 35 30 03 30 Set : 04 31 31 02 36 35 31 03 31 (Unit no. 11, command in hex)	If 1 is written at code 65, the command is set.
Modbus	Cell FF02 (hex)	Release : 07 06 FF 02 00 00 18 78 Set : 07 06 FF 02 00 01 D9 B8 (Modbus address = 7, command in hex)	If 1 is written to cell FF02, the command is set.

8.3. Release Out 1

The Release Out 1 function releases the digital output 1 again when the self-holding has been activated. For this purpose, parameter Output Release of the output 1 must be switched active.

Tiggering	Parameter	Comment	Addition
Input	Input X Config = 0/1 Input X Function = 3	If Input X Config = 0 is set, the command is triggered on a "low" state at input X.	The status of the input can be read in the OS Input field.
Lecom	Code 64 (dec)	Release : 04 31 31 02 36 34 30 03 31 Set : 04 31 31 02 36 34 31 03 30 (Unit no. 11, command in hex)	If 1 is written at code 64, the command is set.
Modbus	Cell FF04 (hex)	Release : 07 06 FF 04 00 00 F8 79 Set : 07 06 FF 04 00 01 39 B9 (Modbus address = 7, command in hex)	If 1 is written to cell FF04, the command is set.

8.4. Release Out 2

The Release Out 2 function releases the digital output 2 again when the self-holding has been activated. For this purpose, parameter Output Release of the output 2 must be switched active.

Tiggering	Parameter	Comment	Addition
Input	Input X Config = 0/1 Input X Function = 4	If Input X Config = 0 is set, the command is triggered on a "low" state at input X.	The status of the input can be read in the OS Input field.
Lecom	Code 63 (dec)	Release : 04 31 31 02 36 33 30 03 36 Set : 04 31 31 02 36 33 31 03 37 (Unit no. 11, command in hex)	If 1 is written at code 63, the command is set.
Modbus	Cell FF06 (hex)	Release : 07 06 FF 06 00 00 59 B9 Set : 07 06 FF 06 00 01 98 79 (Modbus address = 7, command in hex)	If 1 is written to cell FF06, the command is set.

8.5. Release Out 3

The Release Out 3 function releases the digital output 3 again when the self-holding has been activated. For this purpose, parameter Output Release of the output 3 must be switched active.

Tiggering	Parameter	Comment	Addition
Input	Input X Config = 0/1 Input X Function = 5	If Input X Config = 0 is set, the command is triggered on a "low" state at input X.	The status of the input can be read in the OS Input field.
Lecom	Code 62 (dec)	Release : 04 31 31 02 36 32 30 03 37 Set : 04 31 31 02 36 33 31 03 36 (Unit no. 11, command in hex)	If 1 is written at code 62, the command is set.
Modbus	Cell FF08 (hex)	Release : 07 06 FF 08 00 00 38 7A Set : 07 06 FF 08 00 01 F9 BA (Modbus address = 7, command in hex)	If 1 is written to cell FF08, the command is set.

8.6. Release Out 4

The Release Out 4 function releases the digital output 4 again when the self-holding has been activated. For this purpose, parameter Output Release of the output 4 must be switched active.

Tiggering	Parameter	Comment	Addition
Input	Input X Config = 0/1 Input X Function = 6	If Input X Config = 0 is set, the command is triggered on a "low" state at input X.	The status of the input can be read in the OS Input field.
Lecom	Code 61 (dec)	Release : 04 31 31 02 36 31 30 03 34 Set : 04 31 31 02 36 31 31 03 35 (Unit no. 11, command in hex)	If 1 is written at code 61, the command is set.
Modbus	Cell FF0A (hex)	Release : 07 06 FF 0A 00 00 99 BA Set : 07 06 FF 0A 00 01 58 7A (Modbus address = 7, command in hex)	If 1 is written to cell FF0A, the command is set.

8.7. Release Rel 1

The Release Rel 1 function releases the digital relay 1 again when the self-holding has been activated. For this purpose, parameter Output Release of the output REL 1 must be switched active.

Tiggering	Parameter	Comment	Addition
Input	Input X Config = 0/1 Input X Function = 7	If Input X Config = 0 is set, the command is triggered on a "low" state at input X.	The status of the input can be read in the OS Input field.
Lecom	Code 60 (dec)	Release : 04 31 31 02 36 30 30 03 35 Set : 04 31 31 02 36 30 31 03 34 (Unit no. 11, command in hex)	If 1 is written at code 60, the command is set.
Modbus	Cell FF0C (hex)	Release : 07 06 FF 0C 00 00 79 BB Set : 07 06 FF 0C 00 01 B8 7B (Modbus address = 7, command in hex)	If 1 is written to cell FF0C, the command is set.

8.8. Release Rel 2

The Release Rel 2 function releases the digital relay 2 again when the self-holding has been activated. For this purpose, parameter Output Release of the output REL 2 must be switched active.

Tiggering	Parameter	Comment	Addition
Input	Input X Config = 0/1 Input X Function = 8	If Input X Config = 0 is set, the command is triggered on a "low" state at input X.	The status of the input can be read in the OS Input field.
Lecom	Code 59 (dec)	Release : 04 31 31 02 35 39 30 03 3F Set : 04 31 31 02 35 39 31 03 3E (Unit no. 11, command in hex)	If 1 is written at code 59, the command is set.
Modbus	Cell FF0E (hex)	Release : 07 06 FF 0E 00 00 D8 7B Set : 07 06 FF 0E 00 01 19 BB (Modbus address = 7, command in hex)	If 1 is written to cell FF0E, the command is set.

8.9. Release All

The Release All function releases all outputs and all relays again when the self-holding has been activated. For this purpose, parameter Output Release of all outputs must be switched active.

Tiggering	Parameter	Comment	Addition
Input	Input X Config = 0/1 Input X Function = 9	If Input X Config = 0 is set, the command is triggered on a "low" state at input X.	The status of the input can be read in the OS Input field.
Lecom	Code 58 (dec)	Release : 04 31 31 02 35 38 30 03 3E Set : 04 31 31 02 35 38 31 03 3F (Unit no. 11, command in hex)	If 1 is written at code 58, the command is set.
Modbus	Cell FF10 (hex)	Release : 07 06 FF 10 00 00 B8 7D Set : 07 06 FF 10 00 01 79 BD (Modbus address = 7, command in hex)	If 1 is written to cell FF10, the command is set.

9. Output Functions

All output functions can be inverted by parameter Output Polarity. A self-holding can be activated by parameter Output Release. The status of the outputs is directly visible in the Outputs field of the OS. (white = low, blue = high)

9.1. Output Function = 1

If Output Source > Preselec, the output is set high. A programmable hysteresis in % prevents signal changes in case of movements around the switching point. The output is set to low when the value is decreased by the hysteresis.

9.2. Output Function = 2

If the amount of Output Source > Preselec, the output is set high. A programmable hysteresis in % prevents signal changes in case of movements around the switching point. The output is set to low when the value is decreased by the hysteresis.

9.3. Output Function = 3

If Output Source < Preselec, the output is set high. A programmable hysteresis in % prevents signal changes in case of movements around the switching point. The output is set to low when the value is increased by the hysteresis

9.4. Output Function = 4

If the amount of Output Source < Preselec, the output is set high. A programmable hysteresis in % prevents signal changes in case of movements around the switching point. The output is set to low when the value is increased by the hysteresis.

9.5. Output Function = 5

If Output Source is outside the range of Preselec +/- hysteresis, the output is set high.

9.6. Output Function = 6

If the amount of Output Source is outside the range of Preselec +/- hysteresis, the output is set high.

9.7. Output Function = 7

If a DMS error is detected, the output is set. A DMS error is output in case of overcurrent at the DMS supply and in case of an incorrect DMS resistance.

Example:

Output Function = 1

Preselection = 2000,

Output Hysteresis = 10

It results with $2000 \times 10/100 = 200$

The output is set to high when greater than 2000, and is set to low when less than 1800

Output Function = 5

Preselection = 2000,

Output Hysteresis = 10

It results with $2000 \times 10/100 = 200$

The output is set to high in the range 1800 to 2200, outside it is set to low.

10. Lecom Protocol

If you communicate with the unit by the Lecom protocol, you have full read and write access to all internal parameters, states and actual values. The counter uses the Lecom protocol according to DIN ISO 1745. The serial access codes for all parameters of the unit are specified in the parameter list.

10.1. Lecom Read

To request data from the unit, the following request string must be sent:

EOT	AD1	AD2	C1	C2	ENQ
EOT = control character (Hex 04) AD1 = unit address, High Byte AD2 = unit address, Low Byte C1 = code to be read, High Byte C2 = code to be read, Low Byte ENQ = control character (Hex 05)					

If the current register value, for example, should be read (code position: 1) with the unit address 11 (parameter RS Unit No.), then the detailed request string is:

ASCII-Code:	EOT	1	1	:	1	ENQ
Hexadecimal:	04	31	31	3A	31	05
Binary:	0000 0100	0011 0001	0011 0001	0011 1010	0011 0001	0000 0101

If the request is correct the answer of the unit is:

STX	C1	C2	x x x x x x x	ETX	BCC
STX = control character (Hex 02) C1 = code to be read, High Byte C2 = code to be read, Low Byte xxxxx = data to be read ETX = control character (Hex 03) BCC = block check character					

Leading zeros are not transferred. The Block Check Character (BCC) is formed by an EXCLUSIVE-OR function of all characters from C1 to ETX (each inclusive).

10.2. Lecom Write

To describe a parameter, the following string must be sent:

EOT	AD1	AD2	STX	C1	C2	x x x x x x x	ETX	BCC
EOT = control character (Hex 04) AD1 = unit address, High Byte AD2 = unit address, Low Byte STX = control character (Hex 02) C1 = code to be described, High Byte C2 = code to be described, Low Byte xxxxx = sent parameter value ETX = control character (Hex 03) BCC = block check character								

The Block Check Character (BCC) is formed by an EXCLUSIVE-OR function of all characters from C1 to ETX (each inclusive). If the reception is correct, the unit responds with the control character ACK, otherwise with NAK or no message. A newly sent parameter is first stored temporarily in the unit without influencing the function. Thus, it is possible to prepare several new parameters in the background while the unit is running.

If the transferred parameters are to be activated, the value "1" must be sent to the "Activate Data" register. This will activate all changed parameters simultaneously.

If the new parameters are to remain permanently stored even after the power supply has been switched off, additionally the value "1" must be sent to the "Store EEPROM" register. Thus, all new data are also stored in the unit. Otherwise, the unit will return to the original parameter set after power up.

Function	Code
Command Activate Data	67
Command Store EEPROM	68

Both commands react dynamically, i.e. it is sufficient to send the value "1" to the corresponding code. After execution, the command is automatically reset

Activate Data on unit 11:

ASCII	EOT	1	1	STX	6	7	1	ETX	BCC
Hex	04	31	31	02	36	37	31	03	33

Store EEPROM on unit 11:

ASCII	EOT	1	1	STX	6	7	1	ETX	BCC
Hex	04	31	31	02	36	38	31	03	3C

11. Modbus Protocol

If you communicate with the unit by the Modbus protocol, you have full read and write access to all internal parameters, states and actual values. The DM uses the Modbus RTU protocol. The serial access codes for all parameters of the unit are listed in the parameter list. With the parameter Modbus Address the Modbus unit address can be set. Allowed here are the settings 1 ... 247.

Attention: The Modbus checksum sequence L/H is just reversed to the data.

The DM supports the function Reading Holding Register (R, FCT = 03), the function Report Slave ID (R, FCT = 11) and the function Preset Single Register (W, FCT = 06).

11.1. Modbus Read

To request data from the unit, the following request string must be sent:

ADR	FCT	STH	STL	CRH	CRL	CRCL	CRCH
ADR = MB address (parameter) FCT = function (Hex 03) STH = start address, High Byte STL = start address, Low Byte CRH = number of registers, High Byte CRL = number of registers, Low Byte CRCL = checksum CRC16, Low Byte CRCH = checksum CRC16, High Byte							

For example, if a parameter (Modbus ST = 00 0C (hex), 32 Bit = 2 Word -> Modbus CRC = 00 02) is to be read from the unit with address 07, the detailed request string is:

Designation:	ADR	FCT	STH	STL	CRH	CRL	CRCL	CRCH
Hexadecimal:	07	03	00	0C	00	02	04	6E
Binary:	0000	0000	0000	0000	0000	0000	0000	0110
	0111	0011	0000	1100	0000	0010	0100	1110

The unit will answer if the request is correct, for example:

ADR	FCT	CB	DATA	CRCL	CRCH
ADR = MB address (parameter)					
FCT = function (Hex 03)					
CB = number of bytes, here 4 bytes					
DATA = data, 4 bytes (32 Bit)					
CRCx = checksum CRC16					

Designation:	ADR	FCT	CB	DATA	CRCL	CRCH
Hexadecimal:	07	03	04	00 00 0F A0	99	BB
Binary:	0000	0000	0000		1001	1011
	0111	0011	0100		1001	1011

The data above corresponds to a read out of the parameter of 4000.

-The function Reading Holding Registers supports 2 Word (32-bit) accesses to the direct parameter addresses (0x0, 0x4, 0x8, 0xC ..)

- The function Reading Holding Register also supports more than 2 Word accesses to the direct parameter addresses (0x0, 0x4, 0x8, 0xC ..) for area readout

11.2. Modbus Write

To describe a parameter, the following request string must be sent:

ADR	FCT	REH	REL	DAH	DAL	CRCL	CRCH
ADR = MB address (parameter)							
FCT = function (Hex 06)							
REH = register address, High Byte							
REL = register address, Low Byte							
DAH = data High Byte							
DAL = data Low Byte							
CRCL = checksum CRC16, Low Byte							
CRCH = checksum CRC16, High Byte							

If for example the unit with address 07 shall be written with the parameter (Modbus ST = 00 0E, 000C (hex), Modbus DA = 00 01, 00 01), then the detailed request string for the High Word Register is:

Designation:	ADR	FCT	REH	REL	DAH	DAL	CRCL	CRCH
Hexadecimal:	07	06	00	0E	00	01	29	AF
Binary:	0000	0000	0000	0000	0000	0000	0010	1010
	0111	0011	0000	1110	0000	0001	1001	1111

The unit will answer if the request is correct:

ADR	FCT	REG	DATA	CRCL	CRCH
ADR = MB address (parameter)					
FCT = function (Hex 06)					
REG = register address					
DATA = data					
CRCx = checksum CRC16					

Designation:	ADR	FCT	REG	DATA	CRCL	CRCH
Hexadecimal:	07	06	00 0E	00 01	29	AF
Binary:	0000	0000			0010	1010
	0111	0110			1001	1111

String for writing the Low Word Register:

Designation:	ADR	FCT	REH	REL	DAH	DAL	CRCL	CRCH
Hexadecimal:	07	06	00	0C	00	01	88	6F
Binary:	0000	0000	0000	0000	0000	0000	1000	0110
	0111	0011	0000	0110	0000	0001	1000	1111

The data corresponds to a written value of the parameter of 65537.(00 04 00 02 hex). The newly sent parameter is first stored temporarily in the unit, without influencing the function. Thus, it is possible to prepare several new parameters in the background while the unit is running.

If the transferred parameters are to be activated, an "Activate Data" must be sent to the unit. This will activate all changed parameters simultaneously.

To execute an "Activate Data", the following string must be sent:

Designation:	ADR	FCT	REH	REL	DAH	DAL	CRCL	CRCH
Hexadecimal:	07	06	FF	FE	00	01	19	88
Binary:	0000	0000	1111	1111	0000	0000	0001	1000
	0111	0011	1111	1110	0000	0001	1001	1000

It must be ensured that a range violation of the parameter does not cause it to be transferred to the buffer. The permissible parameter ranges can be taken from the parameter description.

If the new parameters are to remain permanently stored even after the power supply is switched off, an additional "Store EEPROM" must be sent to the unit. This means that all new data is also stored in the unit. Otherwise, the unit will return to the original parameter set after power up.

To execute a "Store EEPROM" the following string must be sent:

Designation:	ADR	FCT	REH	REL	DAH	DAL	CRCL	CRCH
Hexadecimal:	07	06	FF	FE	00	02	34	49
Binary:	0000	0000	1111	1111	0000	0000	0011	0100
	0111	0011	1111	1110	0000	0010	0100	1001

With negative parameter values such as e.g. -10000, the value must be divided into two 16-bit values and transmitted with two write accesses. (-10000 dec = FFFF D8F0 hex)

An ID can be requested to identify the unit:

To request an ID, the following string must be sent:

Designation:	ADR	FCT	CRCL	CRCH
Hexadecimal:	07	11	C3	8C
Binary:	0000	0001	1100	1000
	0111	0001	0011	1100

The answer of the unit is if the request is correct:

Designation:	ADR	FCT	BYTE	ID	RUN	DATA	CRCL	CRCH
Hexadecimal:	07	11	12	01	FF	44 4D 33 35 30 20 20 20 44 4D 33 35 30 30 31 41	30	05
Binary:	0000	0001	0001	0000	1111		0011	0000
	0111	0000	0020	0001	1111		0000	0101

44 4D 33 35 30 30 31 41 corresponds in ASCII format : DM35001A

Here the unit header, which is also visible in the OS, is displayed. It identifies the unit (DM350) with software version (01A) and, if available, the special number.

Splitting of the memory area:

Memory address (dec)	MODBUS-FCT	R-access	Read / Write	Note
0...475 0...472 (32 Bit)	03 (R) 06 (W)	2-236 Words 1 Word	R/W	Parameter area
1000..1127 1000..1124 (32 Bit)	03 (R)	2-64 Words	Read only	Variable area
FF00 – FF10 FFFE (hex, 16 Bit)	06 (W) 06 (W)	1 Word 1 Word	Write only Write only	Command area

12. Parameter List

No.	Parameter	Min – value	Max – value	Default	Places	Decimal places	Lecom Code	Modbus Code
General Menu								
000	Filter	0	9	5	1	0	00	L000/H002
001	Scale Units	0	15	0	2	0	01	L004/H006
002	Decimal Point	0	7	3	1	0	02	L008/H00A
003	Pin Preselection	0000	9999	0000	4	0	03	L00C/H00E
004	Pin Parameter	0000	9999	0000	4	0	04	L010/H012
005	Factory Setting	0	1	0	1	0	05	L014/H016
006	Calculation Mode	0	1	0	1	0	06	L018/H01A
007	Disable Set Key	0	1	0	1	0	07	L01C/H01E
008	Reserved	0	10000	1000	5	0	08	L020/H022
Sensor Menu								
009	Sensor Supply	3	10	5	2	0	A0	L024/H026
010	Sensor Gain	0	4	0	1	0	A1	L028/H02A
011	Sensor OSR	0	12	5	2	0	A2	L02C/H02E
012	Sensor Offset	-10000	+10000	0	85	0	A3	L030/H032
013	Sensor Resistor	0	10000	1000	5	0	A4	L034/H036
014	Sensor Sensitivity	0.100	20.000	1.000	5	3	A5	L038/H03A
015	Sensor Voltage	1	99999	1000	5	0	A6	L03C/H03E
016	Sensor Digits	1	99999	1000	5	0	A7	L040/H042
017	Sensor Correction	0.900	1.100	1.000	4	3	A8	L044/H046
018	Sensor Polarity	0	1	0	1	0	A9	L048/H04A
019	Reserved	0	10000	1000	5	0	B0	L04C/L04E
Preselection Menu								
020	Preselection 1	-99999999	+99999999	1000	88	0	B1	L050/H052
021	Preselection 2	-99999999	+99999999	2000	88	0	B2	L054/H056
022	Preselection 3	-99999999	+99999999	3000	88	0	B3	L058/H05A
023	Preselection 4	-99999999	+99999999	4000	88	0	B4	L05C/H05E
024	Preselection R1	-99999999	+99999999	5000	88	0	B5	L060/H062
025	Preselection R2	-99999999	+99999999	6000	88	0	B6	L064/H066
026	Reserved	0	10000	1000	5	0	B7	L068/H06A
Output 1 Menu								
027	Output Source	0	1	0	1	0	B8	L06C/H06E
028	Output Function	0	7	1	1	0	B9	L070/H072
029	Output Hysteresis	0	9999	0	4	0	C0	L074/H076
030	Output Polarity	0	1	0	1	0	C1	L078/H07A
031	Output Release	0	1	0	1	0	C2	L07C/H07E
032	Output Event Color	0	3	3	1	0	C3	L080/H082
033	Reserved	0	10000	1000	5	0	C4	L084/H086
Output 2 Menu								
034	Output Source	0	1	0	1	0	C5	L088/H08A
035	Output Function	0	7	1	1	0	C6	L08C/H08E
036	Output Hysteresis	0	9999	0	4	0	C7	L090/H092
037	Output Polarity	0	1	0	1	0	C8	L094/H096
038	Output Release	0	1	0	1	0	C9	L098/H09A
039	Output Event Color	0	3	0	1	0	D0	L09C/H09E
040	Reserved	0	10000	1000	5	0	D1	L0A0/H0A2

Continuation "Parameter List":

No.	Parameter	Min – value	Max – value	Default	Places	Decimal places	Lecom Code	Modbus Code
	Output 3 Menu							
041	Output Source	0	1	0	1	0	D2	LOA4/H0A6
042	Output Function	0	7	1	1	0	D3	LOA8/H0AA
043	Output Hysteresis	0	9999	0	4	0	D4	LOAC/H0AE
044	Output Polarity	0	1	0	1	0	D5	LOB0/H0B2
045	Output Release	0	1	0	1	0	D6	LOB4/H0B6
046	Output Event Color	0	3	0	1	0	D7	LOB8/H0BA
047	Reserved	0	10000	1000	5	0	D8	LOBC/H0BE
	Output 4 Menu							
048	Output Source	0	1	0	1	0	D9	LOC0/H0C2
049	Output Function	0	7	1	1	0	E0	LOC4/H0C6
050	Output Hysteresis	0	9999	0	4	0	E1	LOC8/H0CA
051	Output Polarity	0	1	0	1	0	E2	LOCC/H0CE
052	Output Release	0	1	0	1	0	E3	L0D0/H0D2
053	Output Event Color	0	3	0	1	0	E4	L0D4/H0D6
054	Reserved	0	10000	1000	5	0	E5	L0d8/H0DA
	Relay 1 Menu							
055	Output Source	0	1	0	1	0	E6	L0DC/H0DE
056	Output Function	0	7	1	1	0	E7	L0E0/H0E2
057	Output Hysteresis	0	9999	0	4	0	E8	L0E4/H0E6
058	Output Polarity	0	1	0	1	0	E9	L0E8/H0EA
059	Output Release	0	1	0	1	0	F0	L0EC/H0EE
060	Output Event Color	0	3	0	1	0	F1	L0F0/H0F2
061	Reserved	0	10000	1000	5	0	F2	L0F4/H0F6
	Relay 2 Menu							
062	Output Source	0	1	0	1	0	F3	L0F8/H0FA
063	Output Function	0	7	1	1	0	F4	L0FC/H0FE
064	Output Hysteresis	0	9999	0	4	0	F5	L100/H102
065	Output Polarity	0	1	0	1	0	F6	L104/H106
066	Output Release	0	1	0	1	0	F7	L108/H10A
067	Output Event Color	0	3	3	1	0	F8	L10C/H10E
068	Reserved	0	10000	1000	5	0	F9	L110/H112
	Serial Menu							
069	Serial Unit Nr.	11	99	11	2	0	90	L114/H116
070	Serial Baud Rate	0	2	0	1	0	91	L118/H11A
071	Serial Format	0	9	0	1	0	92	L11C/H11E
072	Serial Init	0	1	0	1	0	9~	L120/H122
073	Serial Protocol	0	1	0	1	0	G0	L124/H126
074	Serial Timer	0.000	60.000	0.000	5	3	G1	L128/H12A
075	Serial Value	0	11	0	2	0	G2	L12C/H12E
076	Serial Page	0	7	0	1	0	~0	L130/H132
077	MB Address	0	247	0	3	0	G3	L134/H136
078	Reserved	0	10000	1000	5	0	G4	L138/H13A

Continuation "Parameter List":

No.	Parameter	Min – value	Max – value	Default	Places	Decimal places	Lecom Code	Modbus Code
Analog Output Menu								
079	Analog Source	0	1	0	1	0	G5	L13C/H13E
080	Analog Mode	0	3	1	1	0	G6	L140/H142
081	Analog Start	-99999999	+99999999	0	88	0	G7	L144/H146
082	Analog End	-99999999	+99999999	10000	88	0	G8	L148/H14A
083	Analog Set	-99999999	+99999999	0	88	0	G9	L14C/H14E
084	Vout Offset	-99	+99	0	82	0	H0	L150/H152
085	Vout Gain	0.9980	1.0020	1.0000	5	4	H1	L154/H156
086	Iout Offset	-99	+99	0	82	0	H2	L158/H15A
087	Iout Gain	0.9980	1.0020	1.0000	5	4	H3	L15C/H15E
088	Reserved	0	10000	1000	5	0	H4	L160/H162
Digital Input Menu								
089	Input 1 Config	0	1	0	1	0	H5	L164/H166
090	Input 1 Function	0	9	0	1	0	H6	L168/H16A
091	Input 2 Config	0	1	0	1	0	H7	L16C/H16E
092	Input 2 Function	0	9	0	1	0	H8	L170/H172
093	Input 3 Config	0	1	0	1	0	H9	L174/H176
094	Input 3 Function	0	9	0	1	0	I0	L178/H17A
095	Reserved	0	10000	1000	5	0	I1	L17C/H17E
Display Menu								
096	Display Color	0	2	0	1	0	I2	L180/H182
097	Display Brightness R	10	99	90	2	0	I3	L184/H186
098	Display Brightness G	10	99	90	2	0	I4	L188/H18A
099	Display Contrast	150	190	160	3	0	I5	L18C/H18E
100	Display Screen Save	0	99	0	2	0	I6	L190/H192
101	Display Update Time	0.100	9.999	0.250	4	3	I7	L194/H196
102	Display Font	0	1	0	1	0	I8	L198/H19A
103	Display Start Screen	0	4	0	1	0	I9	L19C/H19E
104	Display Large Screen	0	5	0	1	0	J0	L1A0/H1A2
105	Reserved	0	10000	1000	5	0	J1	L1A4/H1A6
Adjustment Menu								
106	TCO Analog Output	0	1	0	1	0	J2	L1A8/H1AA
107	TCI Bridge Offset	0.5000	1.5000	1.0000	5	4	J3	L1AC/H1AE
108	TCI Bridge Gain	0.90000	1.10000	1.00000	6	5	J4	L1B0/H1B2
109	Temp. Comp.	0	3	0	1	0	J5	L1B4/H1B6
110	Bridge Supply Adjust	0.8000	1.2000	1.0000	5	4	J6	L1B8/H1BA
111	TCI Offset Inversion	0	1	0	1	0	J7	L1BC/H1BE
112	TCI Gain Inversion	0	1	0	1	0	J8	L1C0/H1C2
113	Temp. Simulation	0	1	0	1	0	J9	L1C4/H1C6
114	Temp. Sim. Value	870	1412	1140	4	0	K0	L1C8/H1CA
115	Bridge Supply Comp.	0	2	0	1	0	K1	L1CC/H1CE
116	Bridge Supply Ref.	2000	11000	5000	5	0	K2	L1D0/H1D2
117	Reserved	0	10000	1000	5	0	K3	L1D4/H1D6

13. Dimensions

Dimensions in mm [inch]

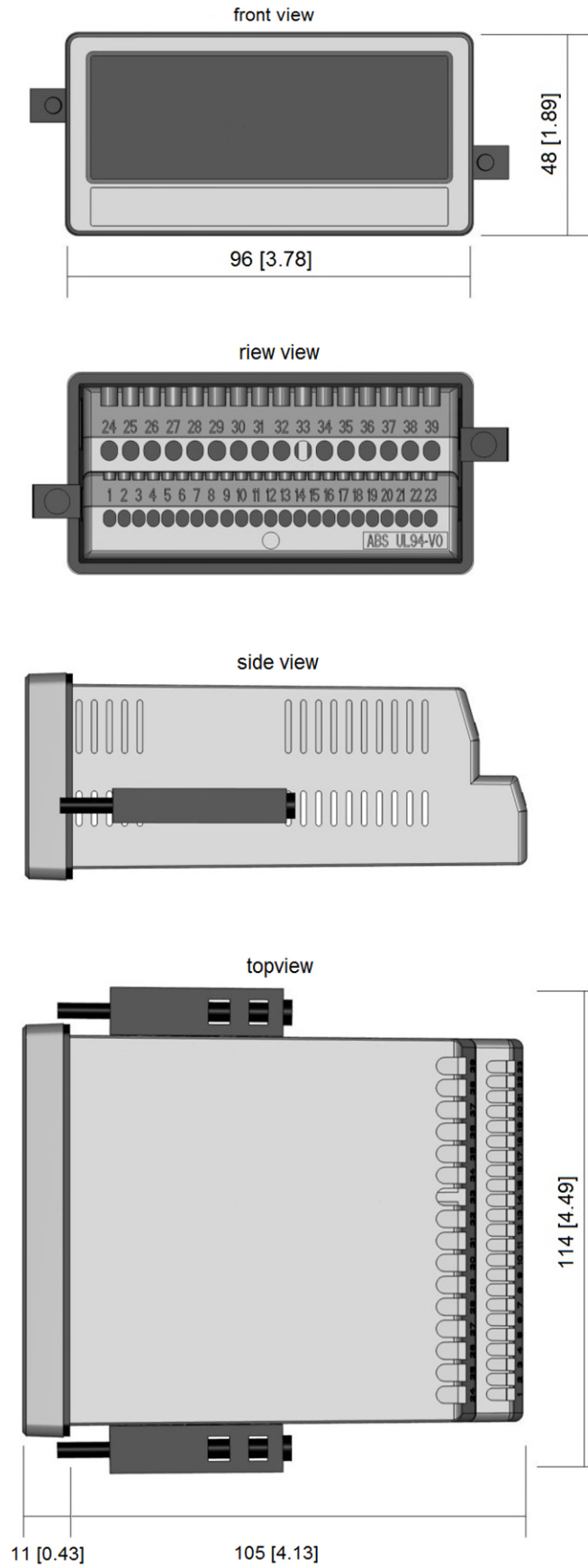

14. Technical Specifications

Technical Specifications:		
Connections:	Connector type:	Screw terminals, 1,5 mm ² / AWG 16
Power supply DC:	Input voltage: Protection circuit: Consumption: Ripple: Fuse protection:	18 ... 30 VDC reverse polarity protection approx. 100 mA (unloaded) ≤ 10 % extern: T 0,5A
Power supply AC: (option AC)	Input voltage: Power consumption: Fuse protection:	115...230 VAC, (50...60 Hz) approx. 3 VA (unloaded) extern: T 0,1 A
DMS supply:	Output voltage: Output current:	3-10 VDC max. 50 mA
DMS inputs:	Configuration: Sensitivity: Resolution: Accuracy:	Voltage input / full bridge +/- 5mV, +/-10mV, +/-20mV, +/-40mV, +/-80mV 16 bit +/- 0.01% / 10K
Control inputs:	Number of inputs: Format: Frequency: Reaction time: Load:	3 HTL, PNP (Low 0 ... 4 V, High 10 ... 30 V) max. 1 kHz 1 ms max. 3mA bei 24VDC
Analog output: (option AO/AR)	Configuration: Voltage output: Current output: Resolution / Accuracy Reaction time:	Current or voltage output -10 ... +10 V (max. 2 mA) 0/4 ... 20 mA (burden max. 270 Ohm) 16 bit / ± 0,1 % depending on the OSR value and the filter
Control outputs: (option AO/AR/CO/CR)	Number of outputs: Format: Output current: Reaction time:	4 5 ... 30 V (depending on voltage at Com+), PNP max. 60 mA < 1 ms
Relay outputs: (option RL)	Number of outputs: Configuration: AC-switching capacity: DC-switching capacity: Reaction time:	2 COM, NO, NC (potential free) max. 250 VAC / 3 A / 750 VA max. 150 VDC / 2 A / 50 W < 20 ms
Serial interface: (option AO/AR/CO/CR)	Format (option AO/CO): Format (option AR/CR) Baud rate: Protocol:	RS232 2-wire RS485 9600, 19200 or 38400 Baud LECOM, MODBUS
Display:	Type: Display range: Digit height (single + dual): Digit height (large display): Color: Operation:	graphic LCD with backlight 8 digits plus sign (-99999999 ... 99999999) 13 mm / 0.51 inch 26 mm / 1.02 inch red/ green/ yellow (switchable) resistive touchscreen
Housing:	Material: Mounting: Dimensions (w x h x d): Cut out (w x h): Protection class: Weight:	ABS, UL 94 V-0 panel 96 x 48 x 116 mm / 3.78 x 1.89 x 4.56 inch 91 x 43 mm / 3.58 x 1.69 inch IP65 (front), IP20 (rear) approx... 200 g
Ambient temperature:	Operation: Storage:	-20 °C ... +60 °C resp. -4 ... 140 °F (non condensing) -25 °C ... +70°C resp. -13 ... 158 °F
Ambient conditions:	Altitude: Humidity: Pollution Degree:	max. 2000 m (6560 ft) above sea level max. 80% relative humidity up to 30°C / 86°F 2
Conformity and standards:	EMC 2014/30/EU: LV 2014/35/EU: (Only for option AC and RL) RoHS (II) 2011/65/EU RoHS (III) 2015/863:	EN 61326-1: 2013 for industrial location EN 55011: 2016 + A1: 2017 + A11: 2020 Class A EN 61010-1: 2020 + A1: 2019 + AC: 2019-04 EN IEC 61010-2-201: 2018 EN IEC 63000: 2018